

# ANYA 2

ARABIAN RANCHES III

HERMAS  
PROPERTIES

---

FLOOR PLANS

---

EMAAR

# ANYA 2

ARABIAN RANCHES III

## LUNA TOWNHOUSE 4 BEDROOM 1

UNIT	TOTAL AREA	
4PLEX - THO!		
6PLEX - THO!	2376.45 SQFT	220.78 SQM
8PLEX - THO!		

### KEY PLAN

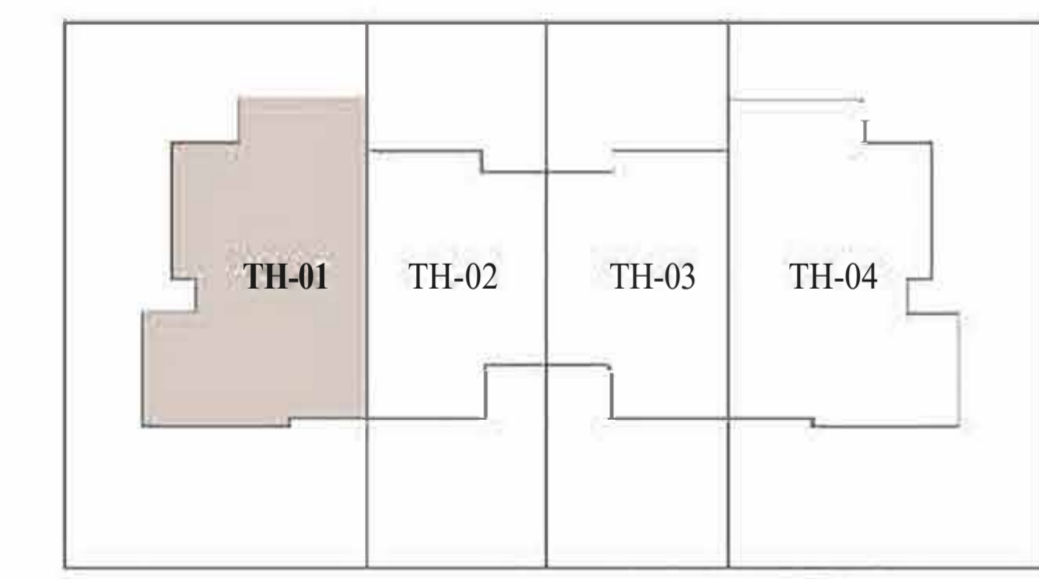

4PLEX - THO!

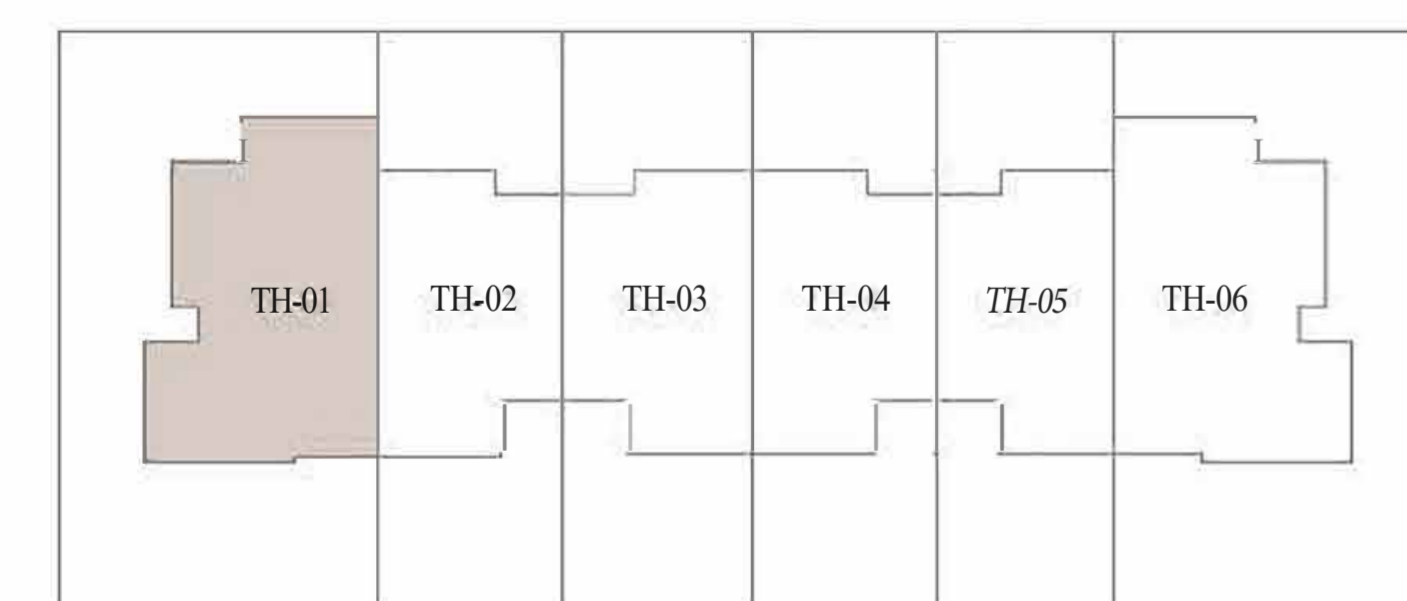

6PLEX - THO!

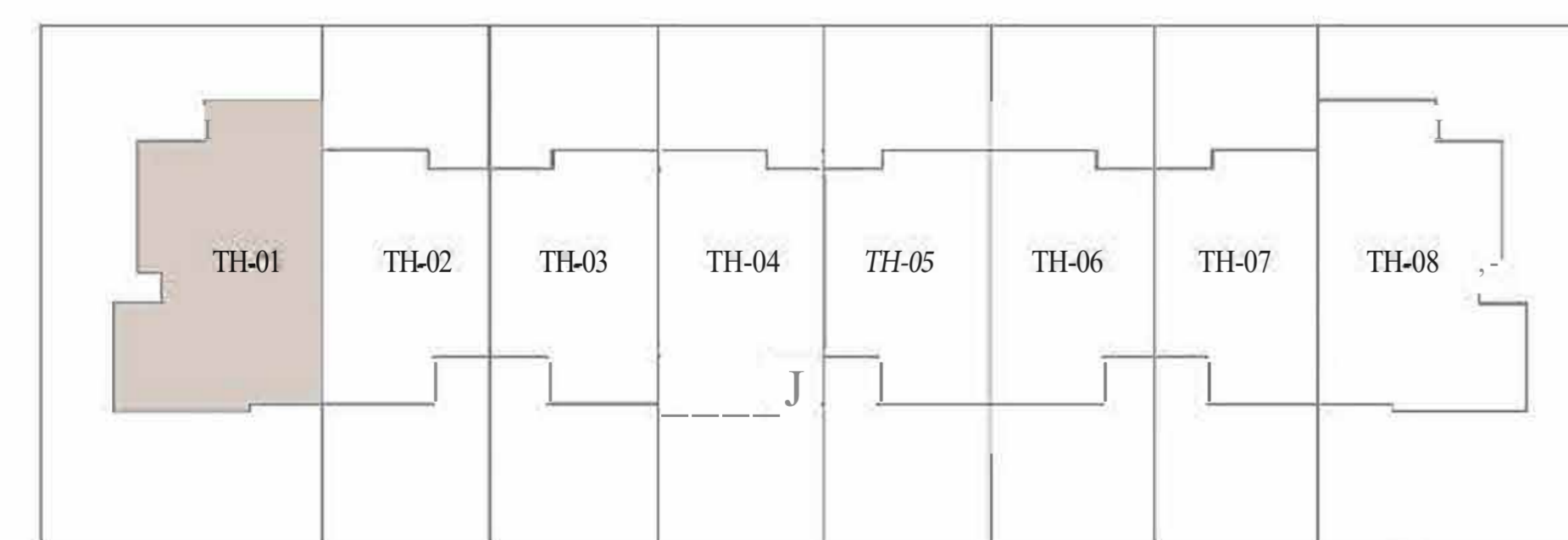

8PLEX - THO!

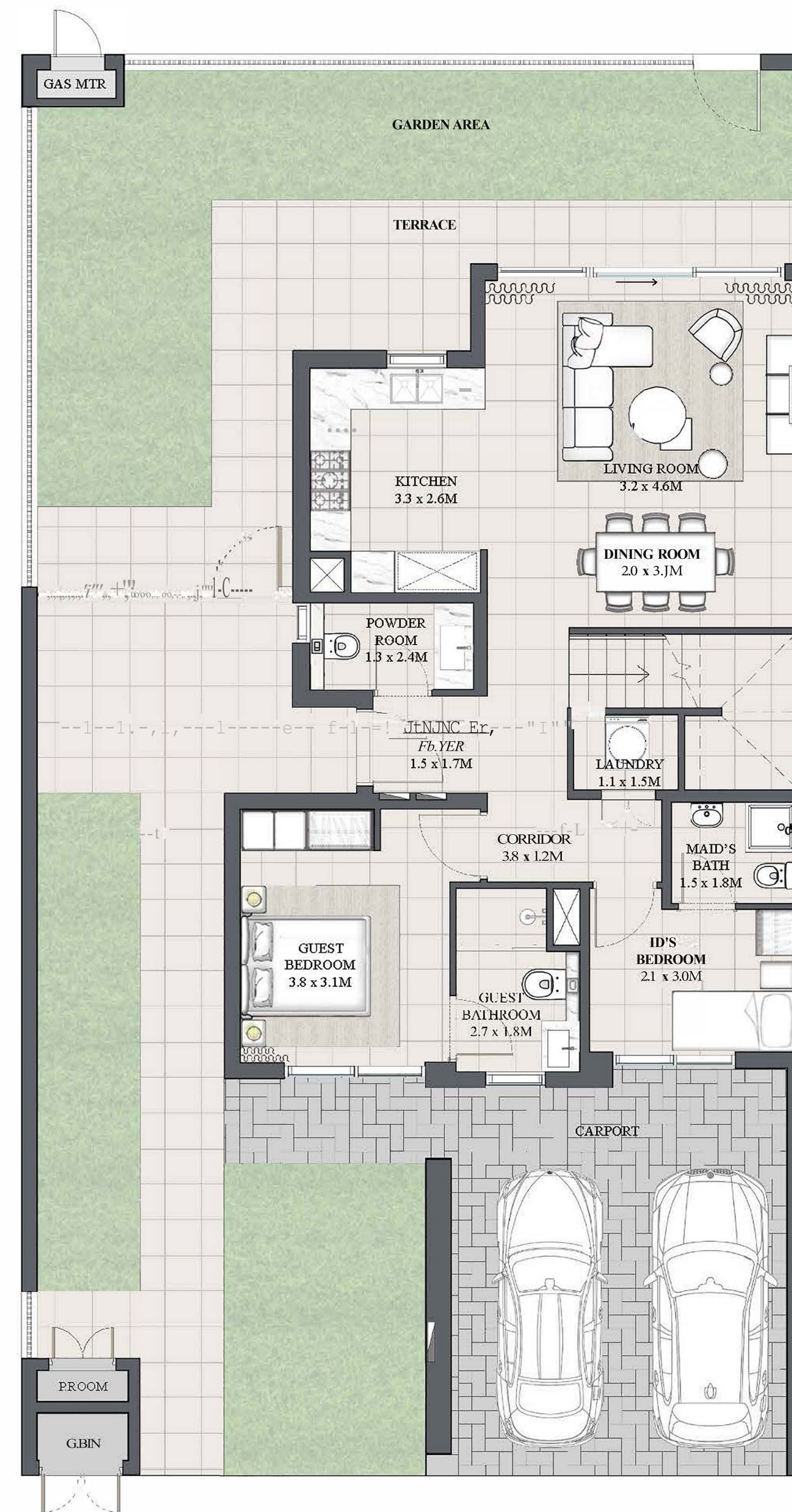

GROUND FLOOR

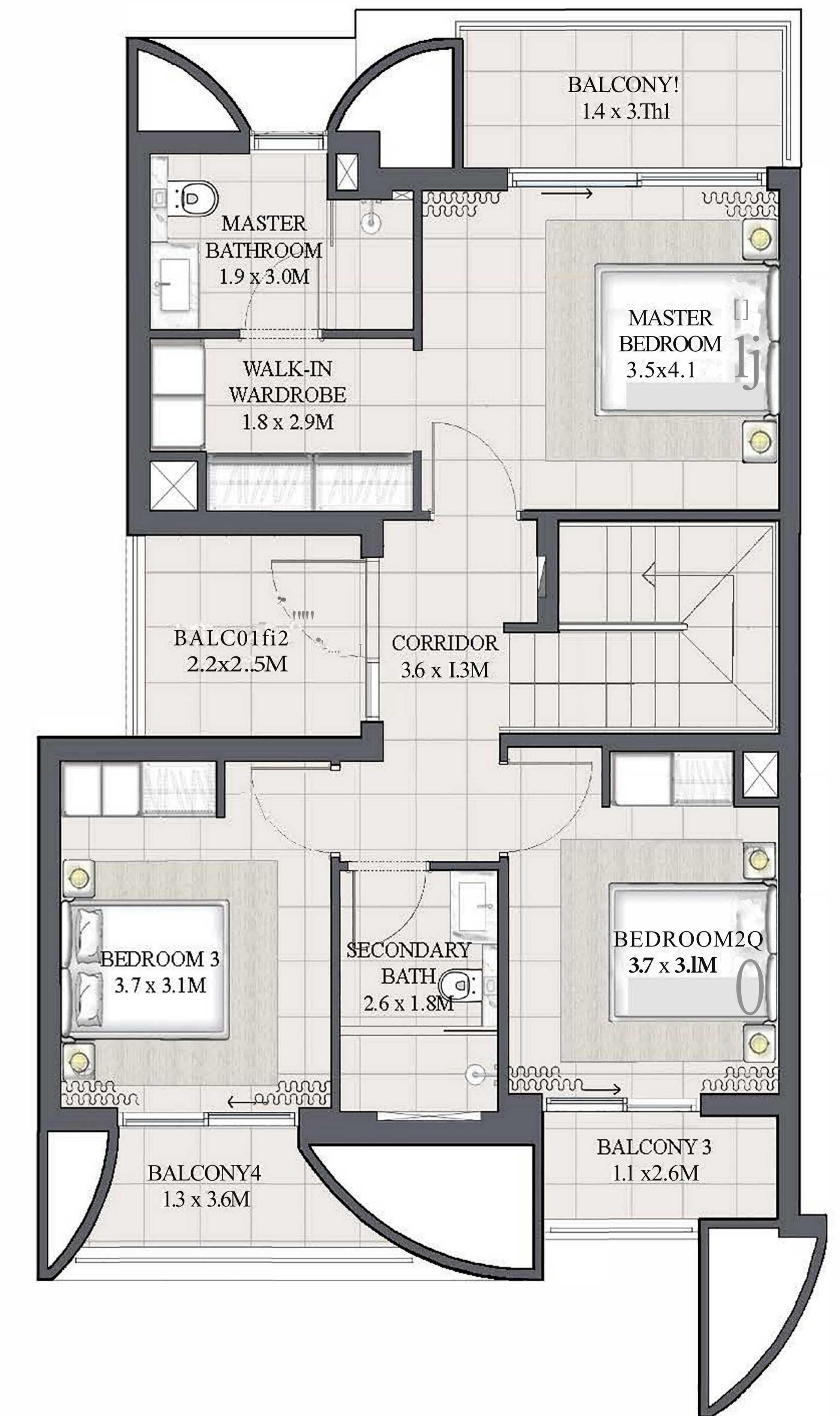

FIRST FLOOR

FLOOR PLAN 1. All dimensions are in imperial and metric, and measured from finish to finish excluding construction tolerances. 2. All materials, dimensions, and drawings are approximate only. 3. Information is subject to change without notice, at developer's absolute discretion. 4. Actual area may vary from the stated area. 5. Drawings not to scale. 6. All images used are for illustrative purposes only and do not represent the actual size, features, specifications, fittings, and furnishings. 7. The developer reserves the right to make revisions / alterations, at it's absolute discretion, without any liability whatsoever.

# ANYA 2

ARABIAN RANCHES III

## LUNA TOWNHOUSE 4 BEDROOM 1 M MIRRORED

UNIT	TOTAL AREA
4PLEX - TH04	
6PLEX - TH06	2376.45 SQFT      220.78 SQM
8PLEX - TH08	

### KEY PLAN

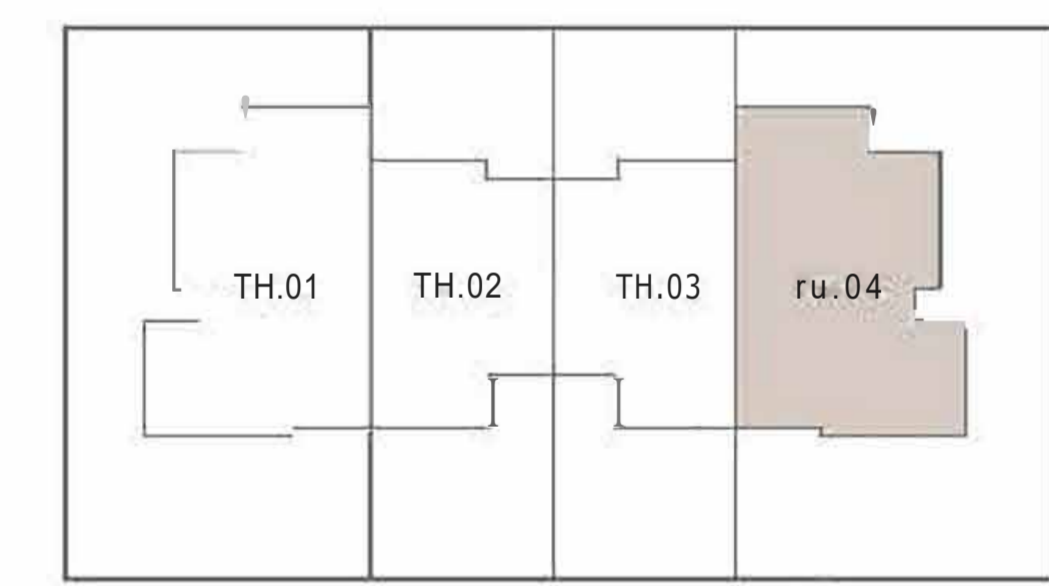

4PLEX - TH04

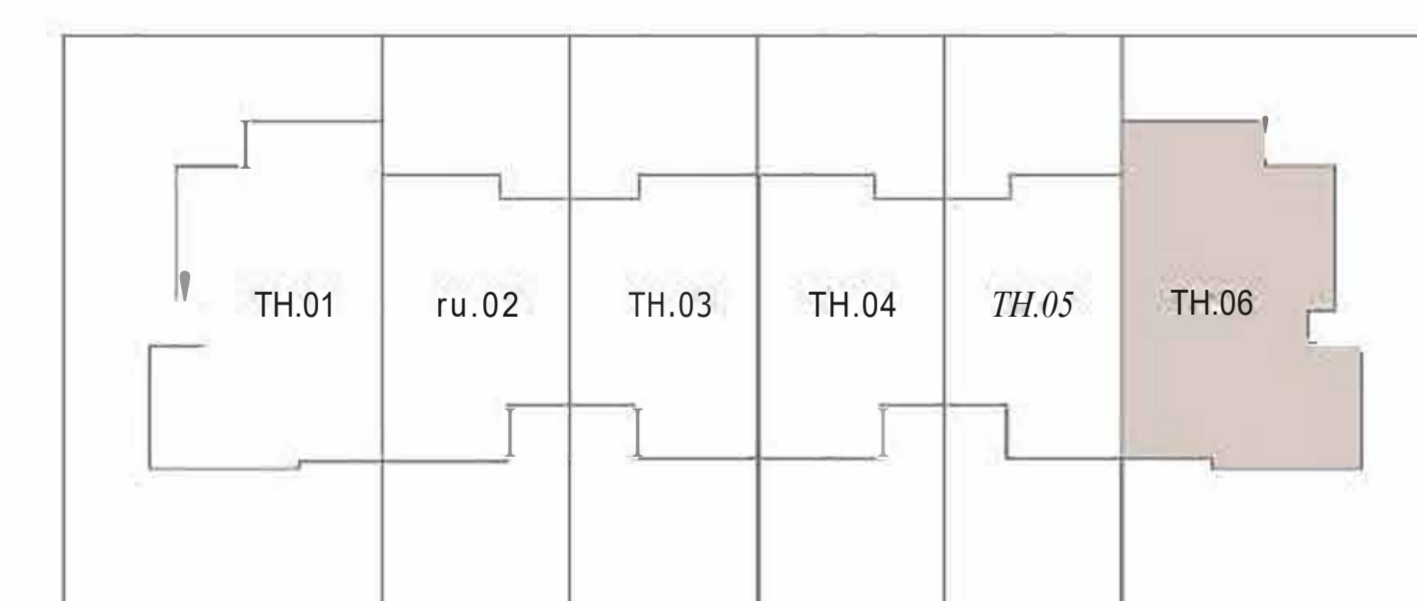

6PLEX - TH06

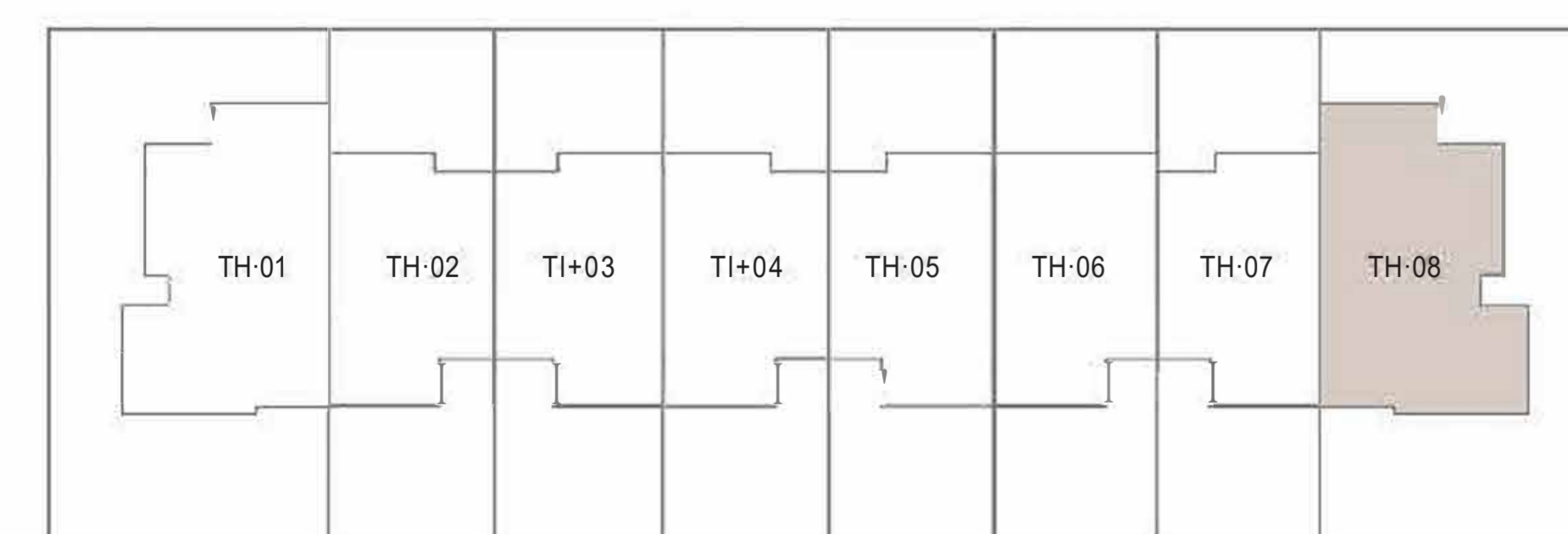

8PLEX - TH08

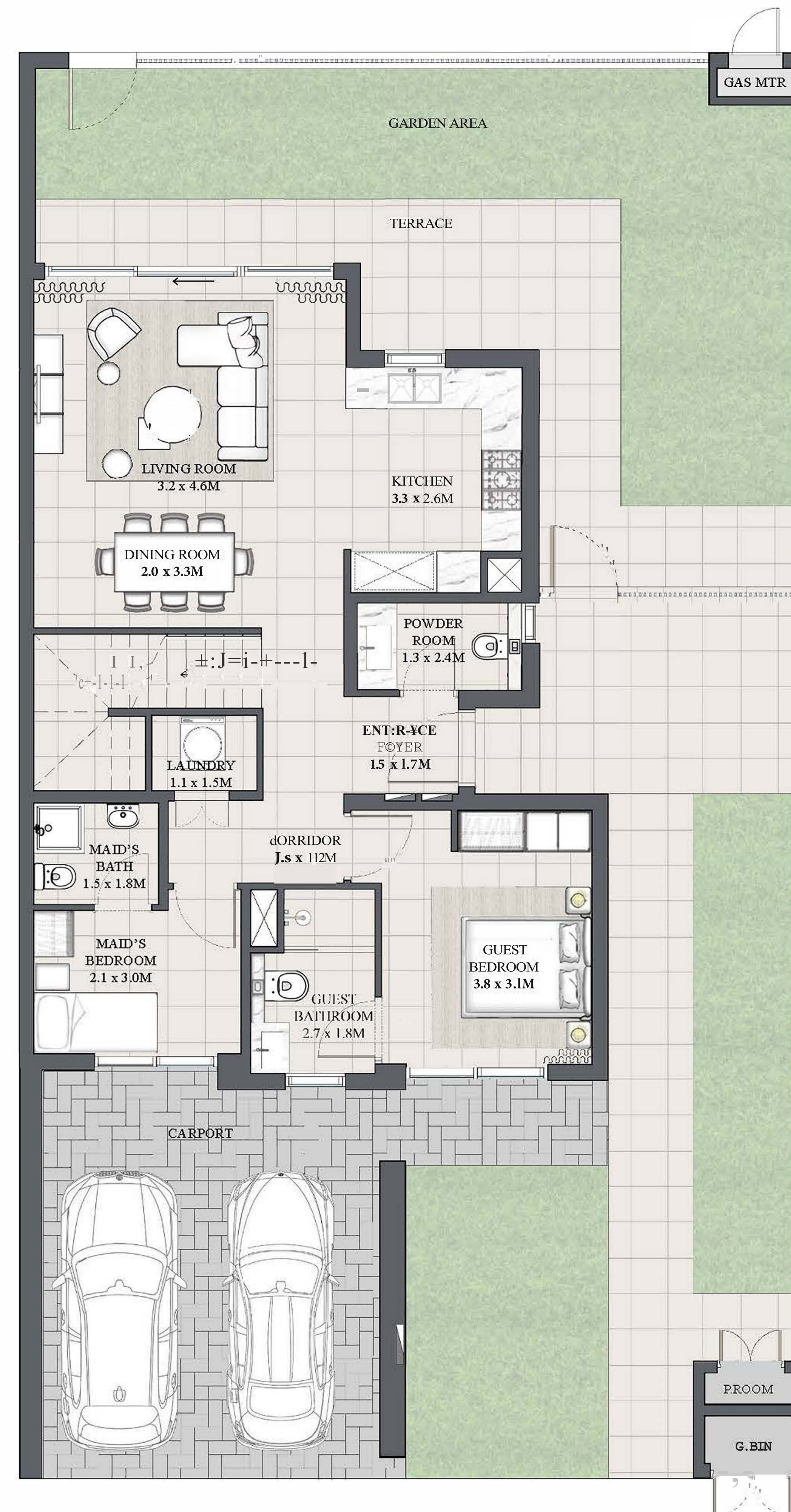

GROUND FLOOR

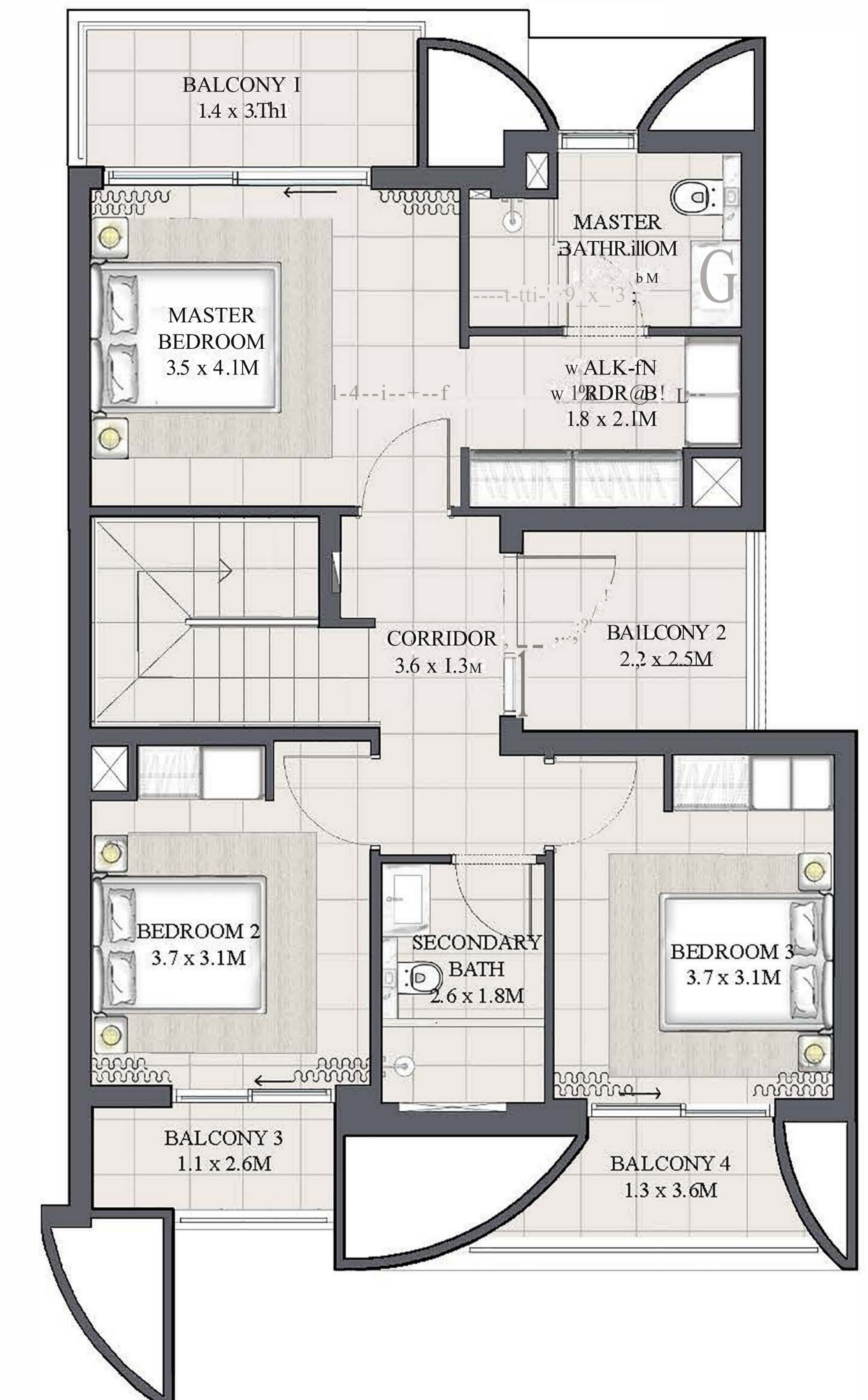

FIRST FLOOR

FLOOR PLAN 1. All dimensions are in imperial and metric, and measured from finish to finish excluding construction tolerances. 2. All materials, dimensions, and drawings are approximate only. 3. Information is subject to change without notice, at developer's absolute discretion. 4. Actual area may vary from the stated area. 5. Drawings not to scale. 6. All images used are for illustrative purposes only and do not represent the actual size, features, specifications, fittings, and furnishings. 7. The developer reserves the right to make revisions / alterations, at it's absolute discretion, without any liability whatsoever.

# ANYA 2

ARABIAN RANCHES III

## LUNA TOWNHOUSE 3 BEDROOM 1

UNIT	TOTAL AREA	
4PLEX - TH02	1918.13 SQFT	178.20 SQM
6PLEX - TH02	1917.59 SQFT	178.15 SQM
8PLEX - TH02		

### KEY PLAN

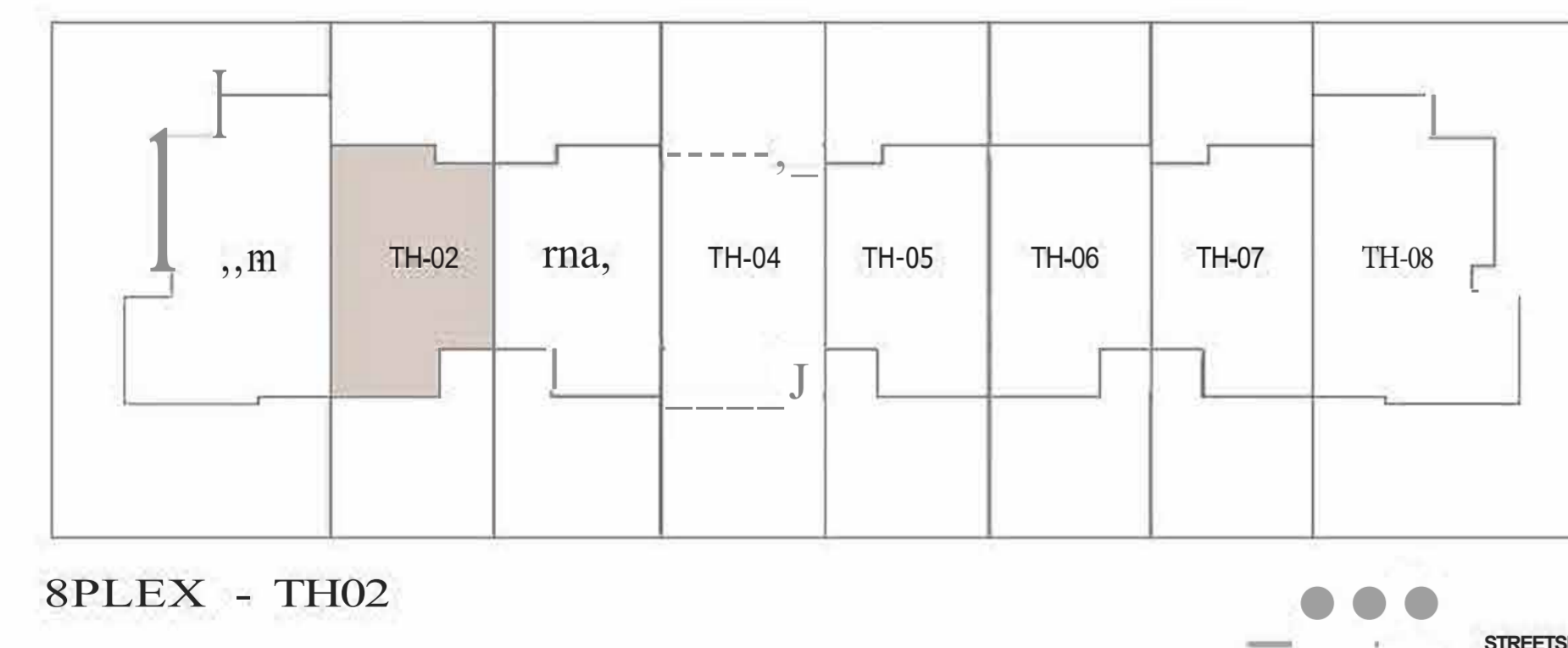
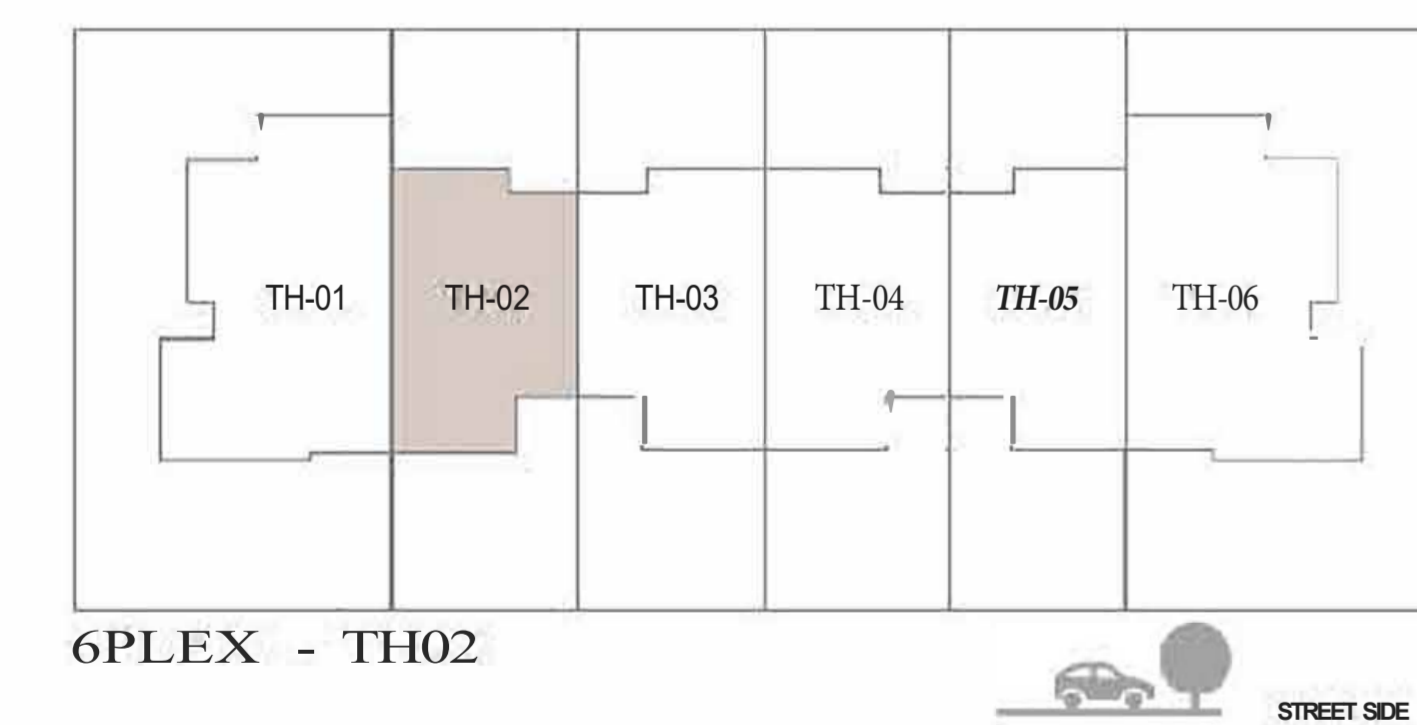
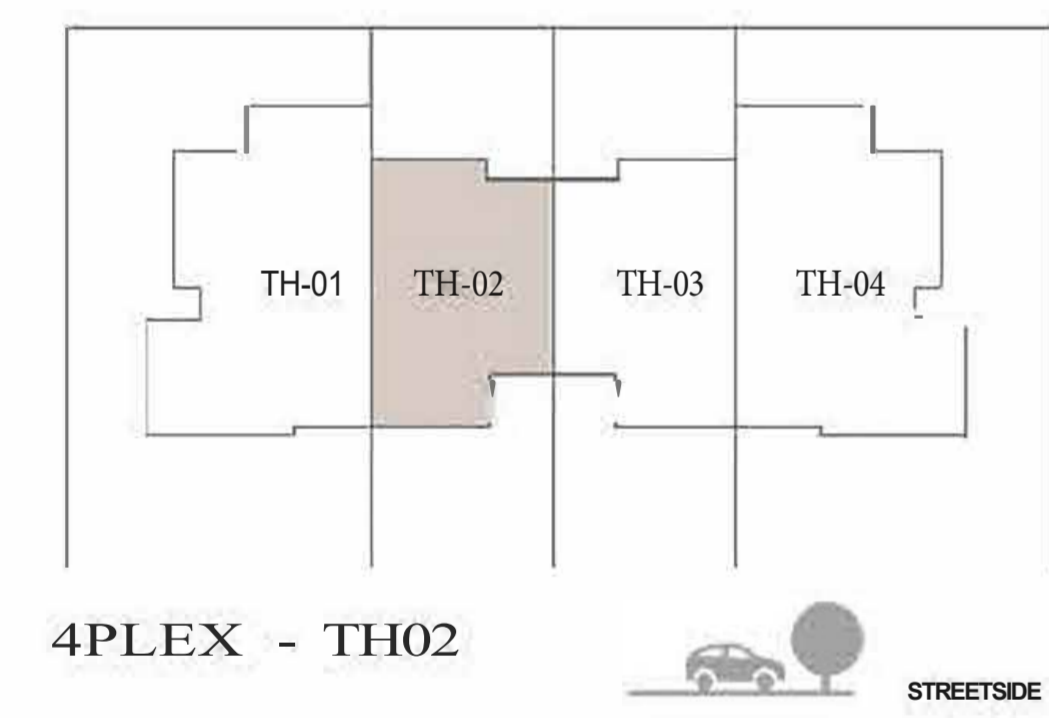

GROUND FLOOR

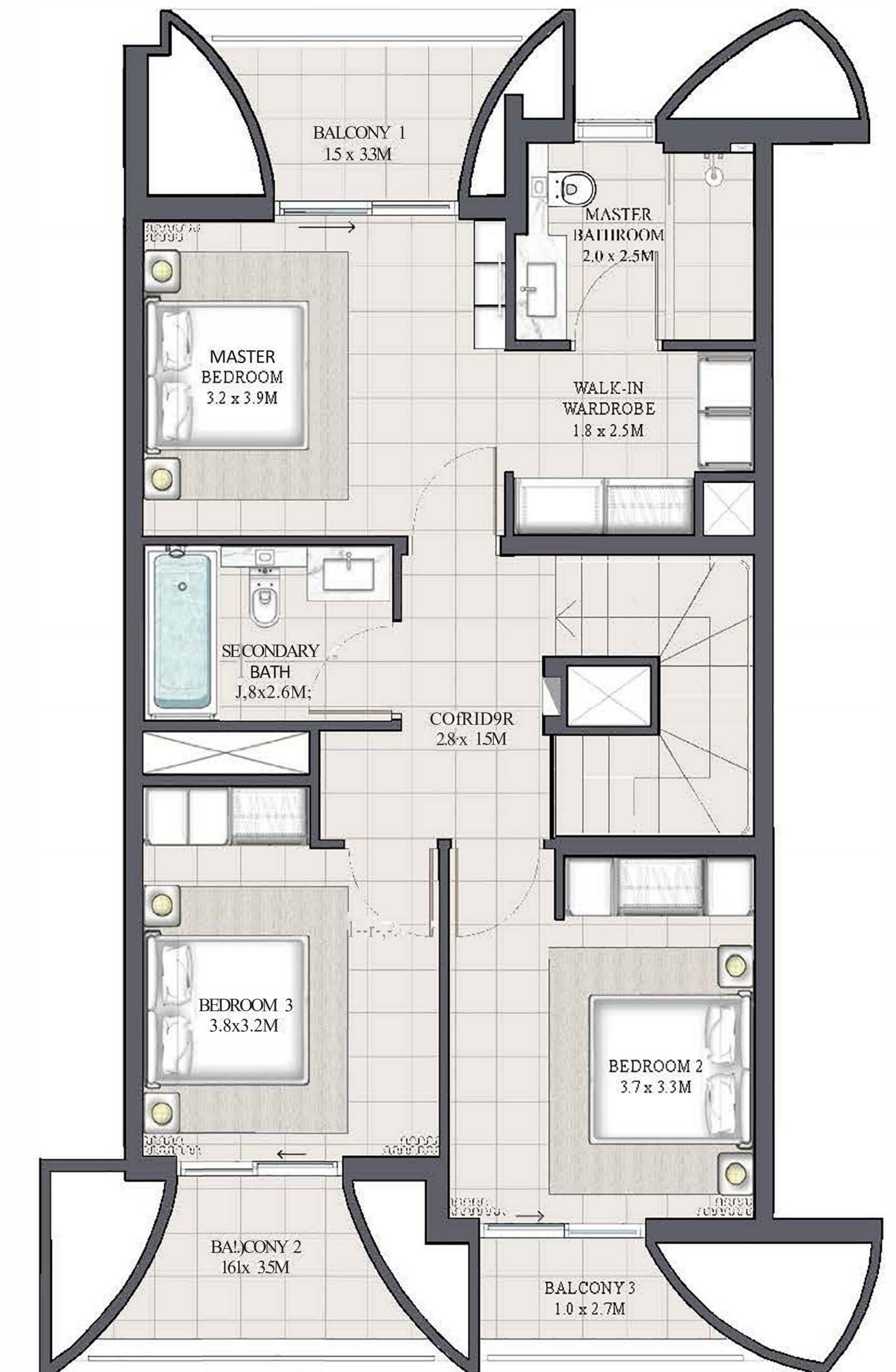

FIRST FLOOR

FLOOR PLAN 1. All dimensions are in imperial and metric, and measured from finish to finish excluding construction tolerances. 2. All materials, dimensions, and drawings are approximate only. 3. Information is subject to change without notice, at developer's absolute discretion. 4. Actual area may vary from the stated area. 5. Drawings not to scale. 6. All images used are for illustrative purposes only and do not represent the actual size, features, specifications, fittings, and furnishings. 7. The developer reserves the right to make revisions / alterations, at it's absolute discretion, without any liability whatsoever.

# ANYA 2

ARABIAN RANCHES III

## LUNA TOWNHOUSE 3 BEDROOM 1 M MIRRORED

UNIT	TOTAL AREA	
6PLEX - TH05	1917.59 SQFT	178.15 SQM
8PLEX - TH07		

### KEY PLAN

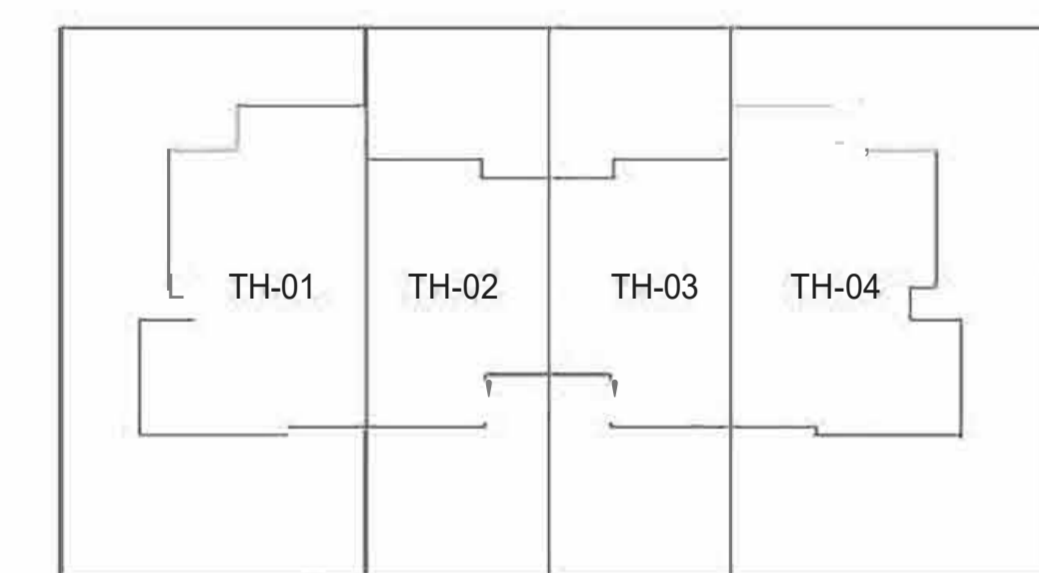

4PLEX

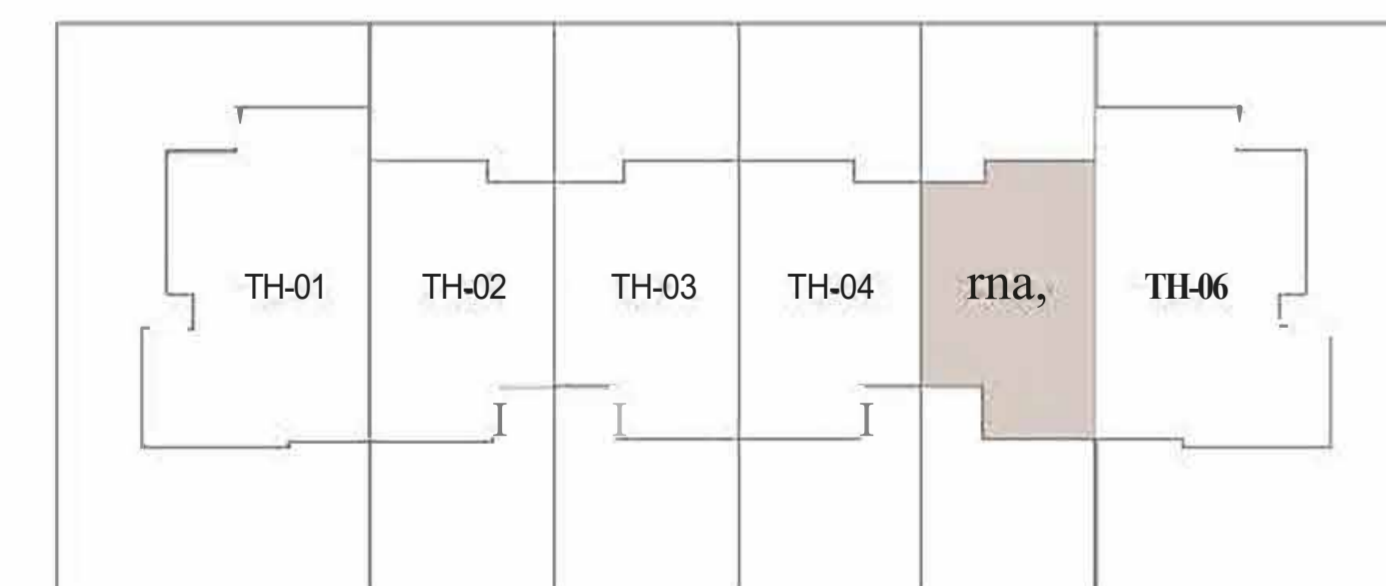

6PLEX - TH05

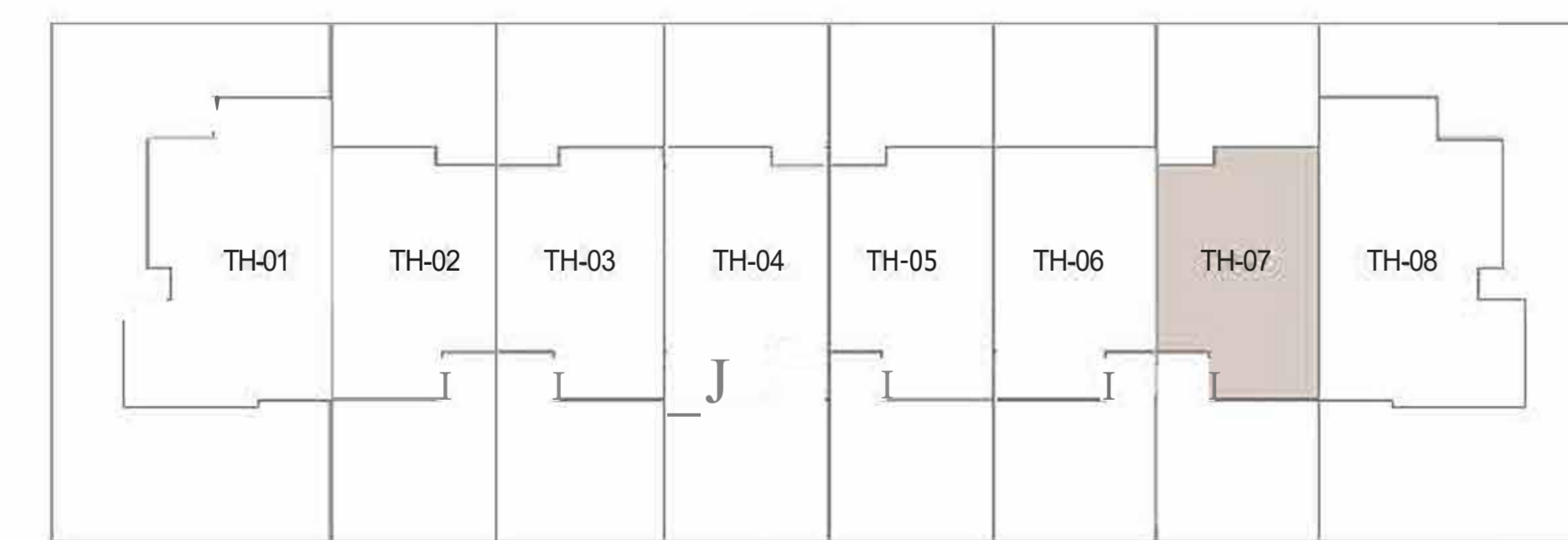

8PLEX - TH07

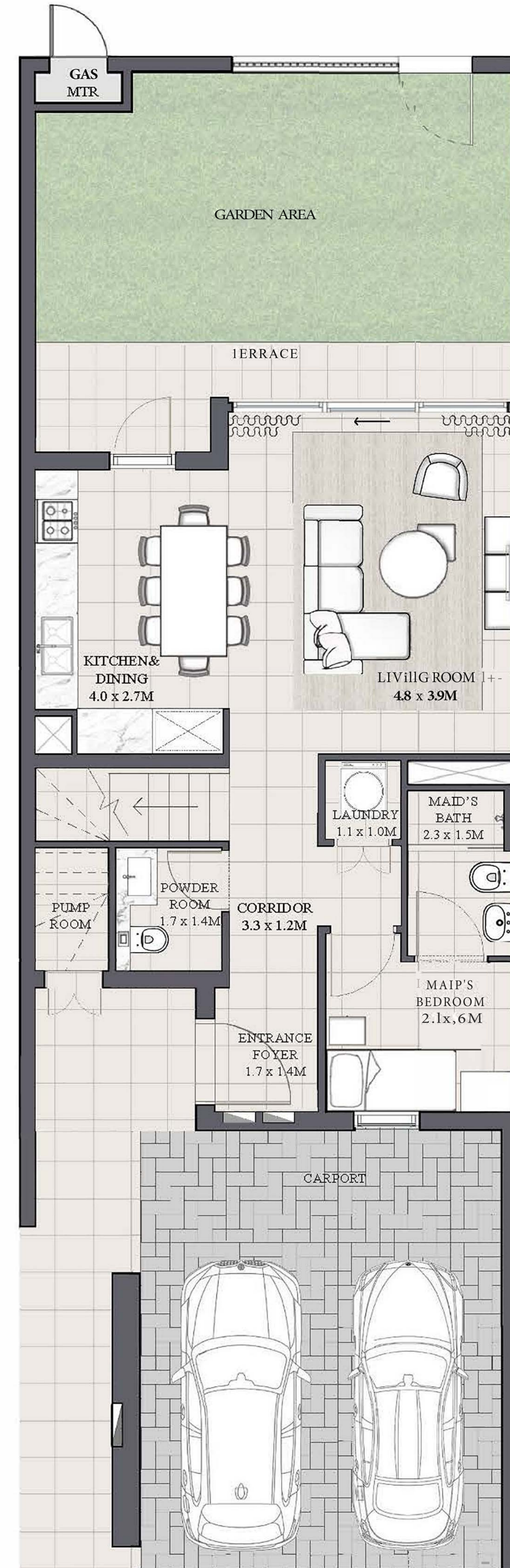

GROUND FLOOR



FIRST FLOOR

FLOOR PLAN 1. All dimensions are in imperial and metric, and measured from finish to finish excluding construction tolerances. 2. All materials, dimensions, and drawings are approximate only. 3. Information is subject to change without notice, at developer's absolute discretion. 4. Actual area may vary from the stated area. 5. Drawings not to scale. 6. All images used are for illustrative purposes only and do not represent the actual size, features, specifications, fittings, and furnishings. 7. The developer reserves the right to make revisions / alterations, at it's absolute discretion, without any liability whatsoever.

# ANYA 2

ARABIAN RANCHES III

LUNA

TOWNHOUSE

3 BEDROOM 2

UNIT	TOTAL AREA	
4PLEX - TH03	1913.18 SQFT	177.74 SQM

## KEY PLAN

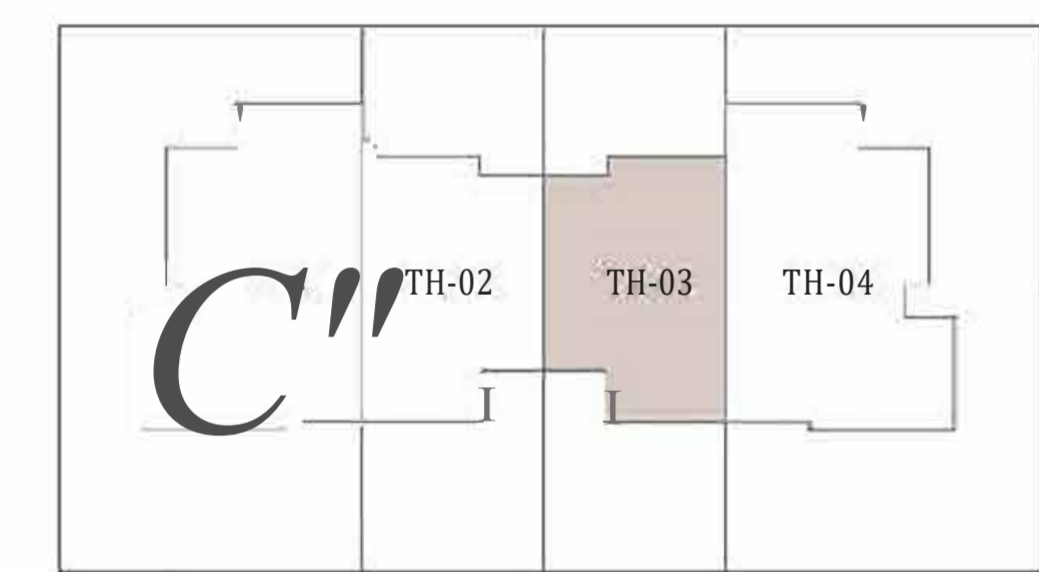

4PLEX - TH03

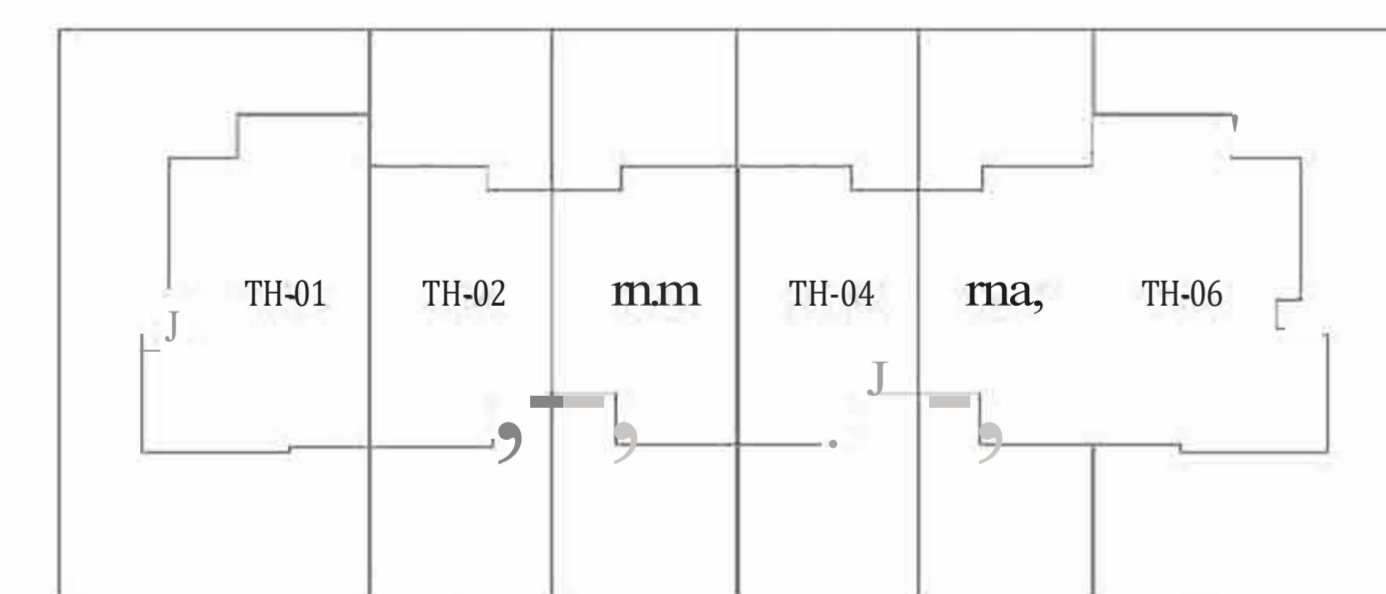

6PLEX

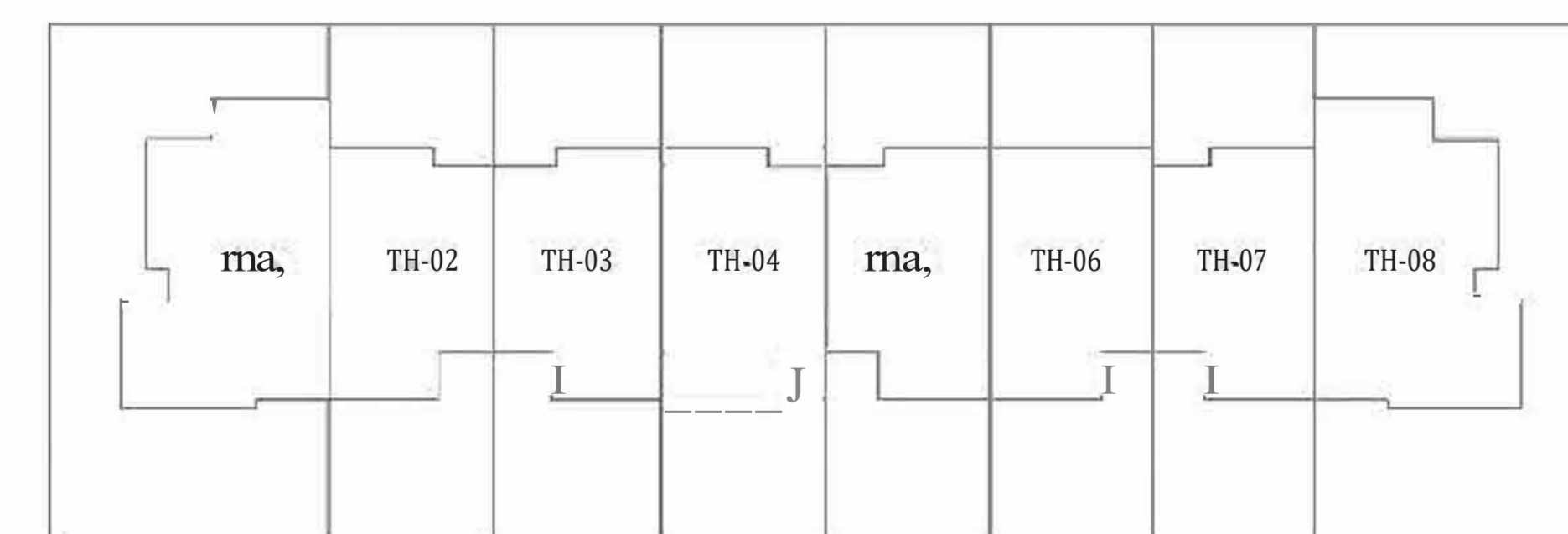

8PLEX

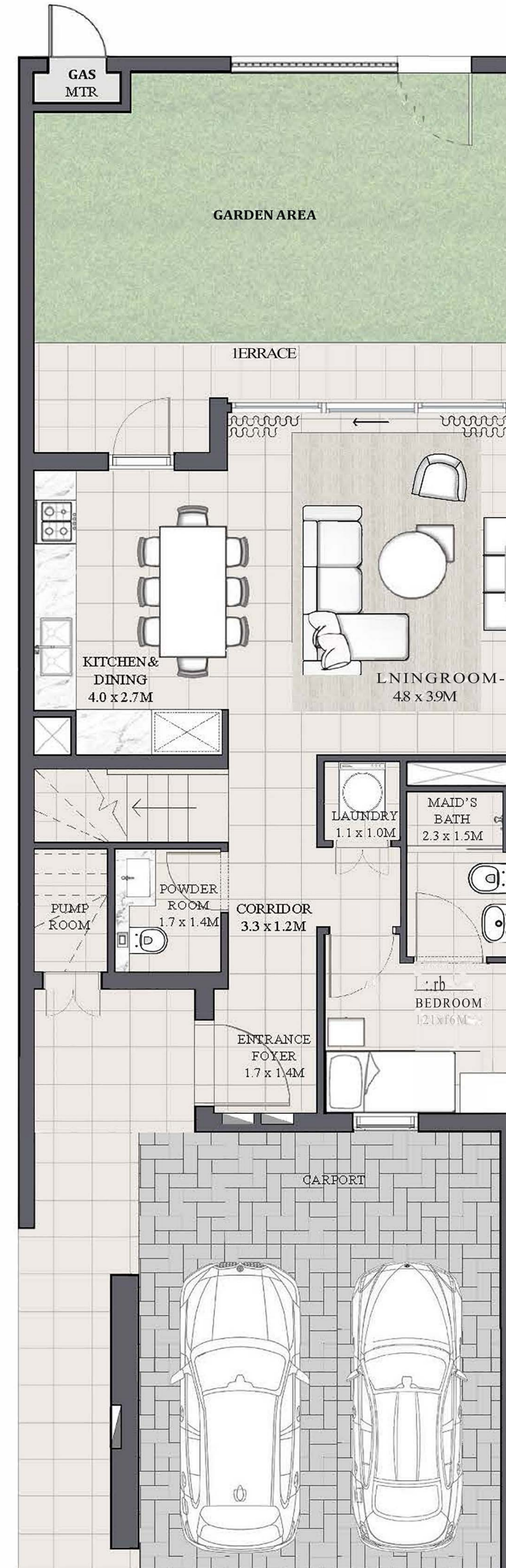

GROUND FLOOR

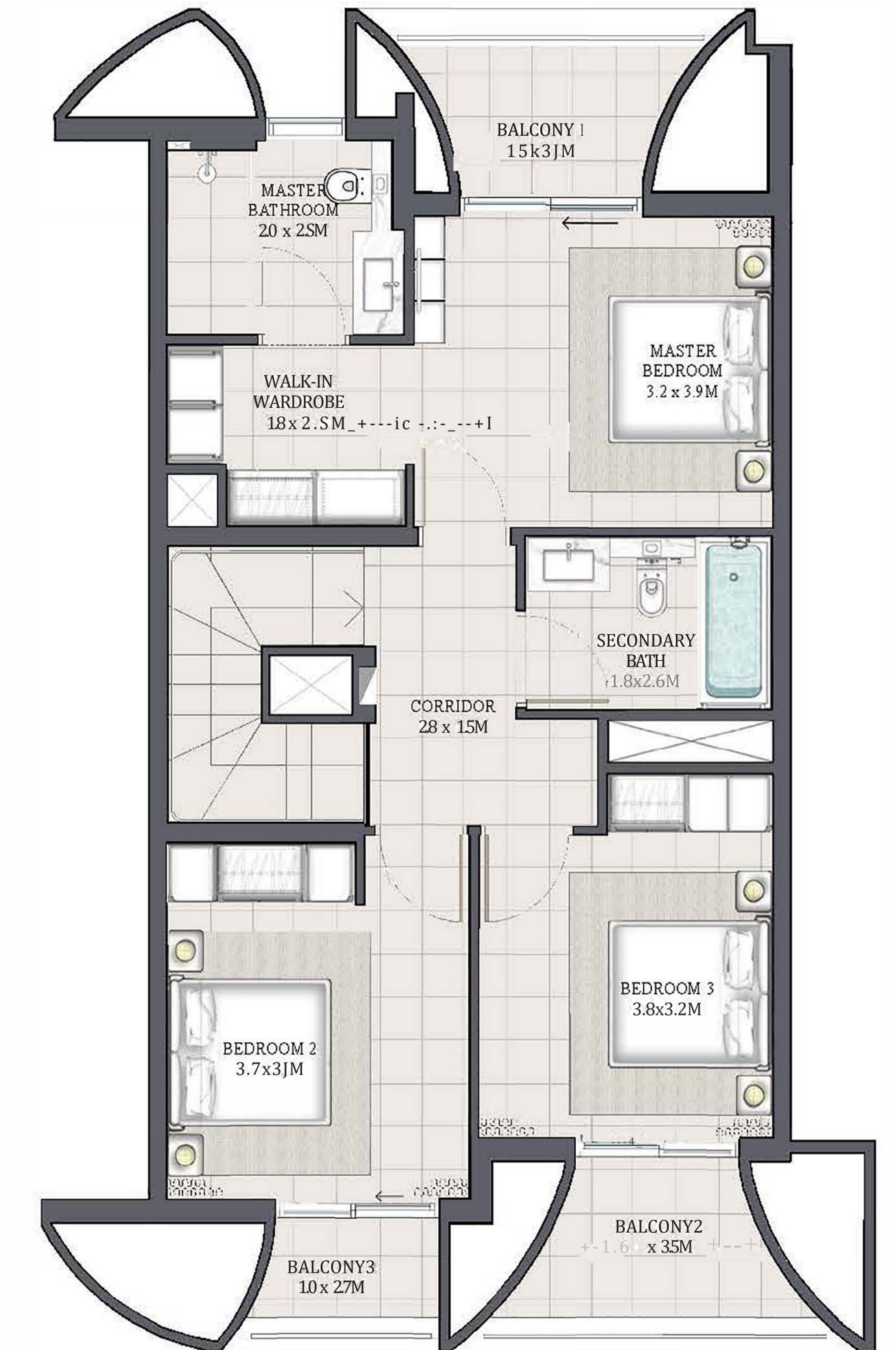

FIRST FLOOR

FLOOR PLAN 1. All dimensions are in imperial and metric, and measured from finish to finish excluding construction tolerances. 2. All materials, dimensions, and drawings are approximate only. 3. Information is subject to change without notice, at developer's absolute discretion. 4. Actual area may vary from the stated area. 5. Drawings not to scale. 6. All images used are for illustrative purposes only and do not represent the actual size, features, specifications, fittings, and furnishings. 7. The developer reserves the right to make revisions / alterations, at it's absolute discretion, without any liability whatsoever.

# ANYA 2

ARABIAN RANCHES III

LUNA

TOWNHOUSE

## 3 BEDROOM 3

UNIT	TOTAL AREA	
6PLEX - TH03	1899.07 SQFT	176.43 SQM

### KEY PLAN

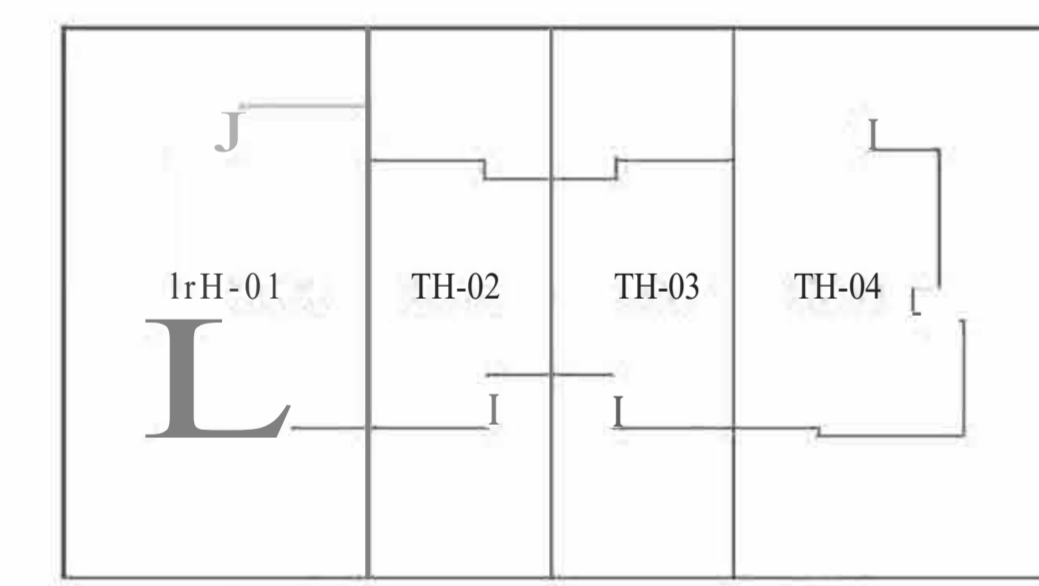

4PLEX

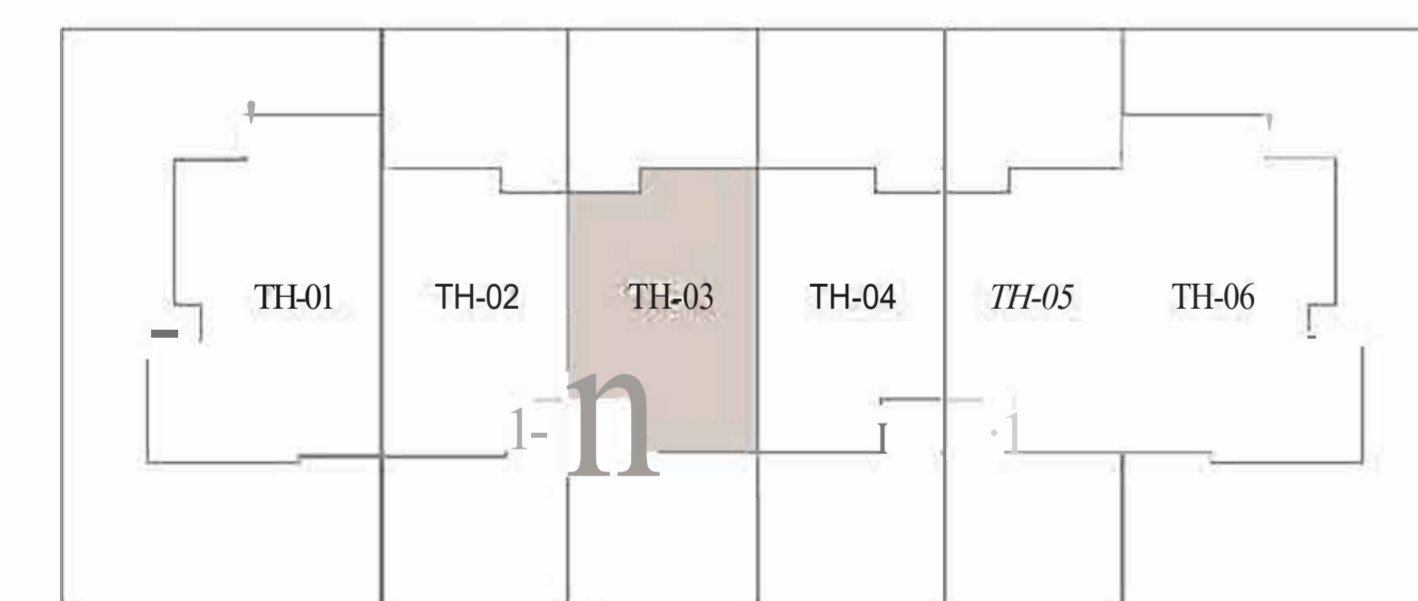

6PLEX - TH03

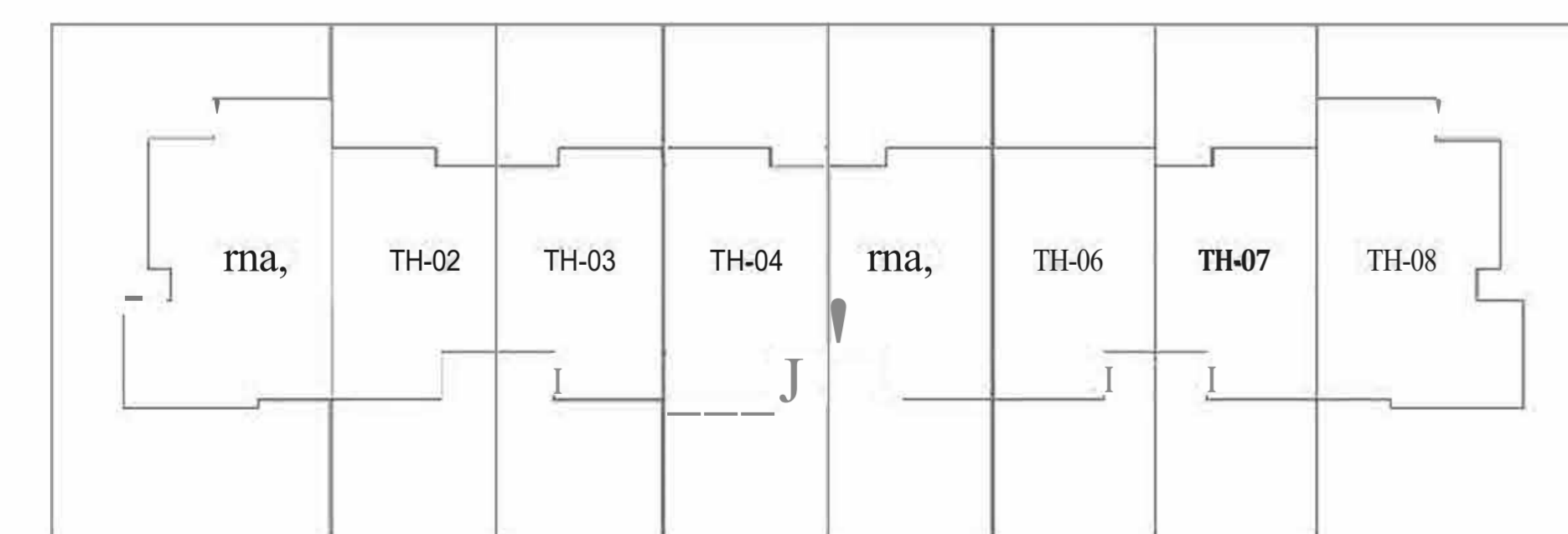

8PLEX

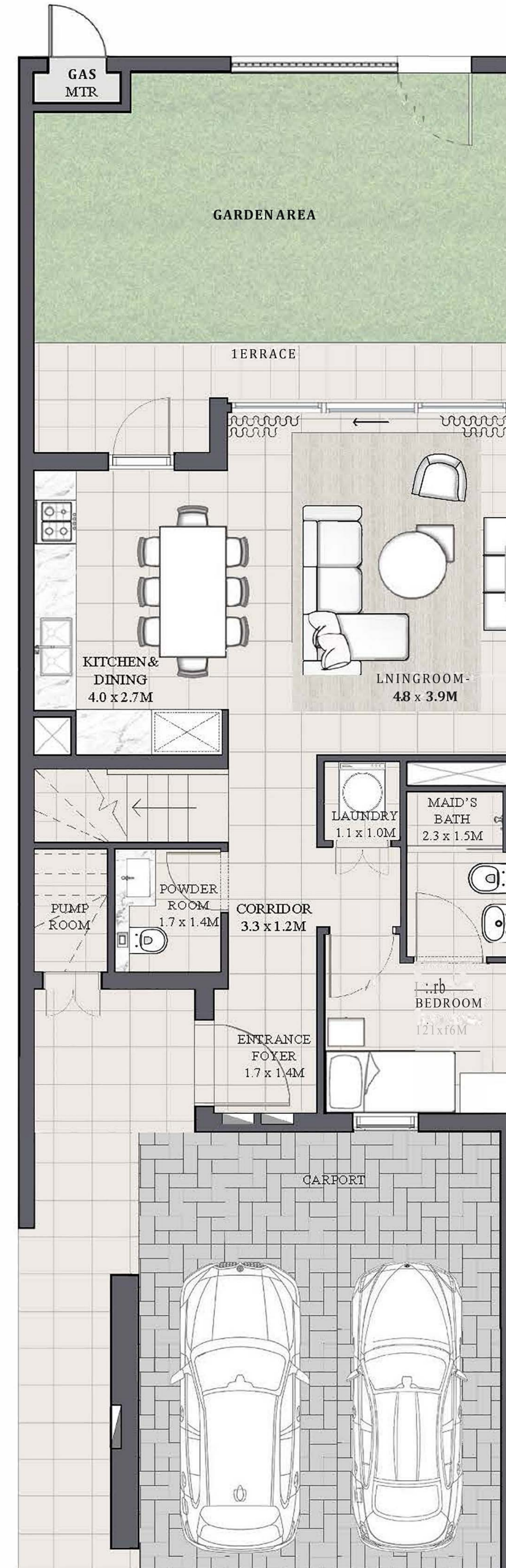

GROUND FLOOR

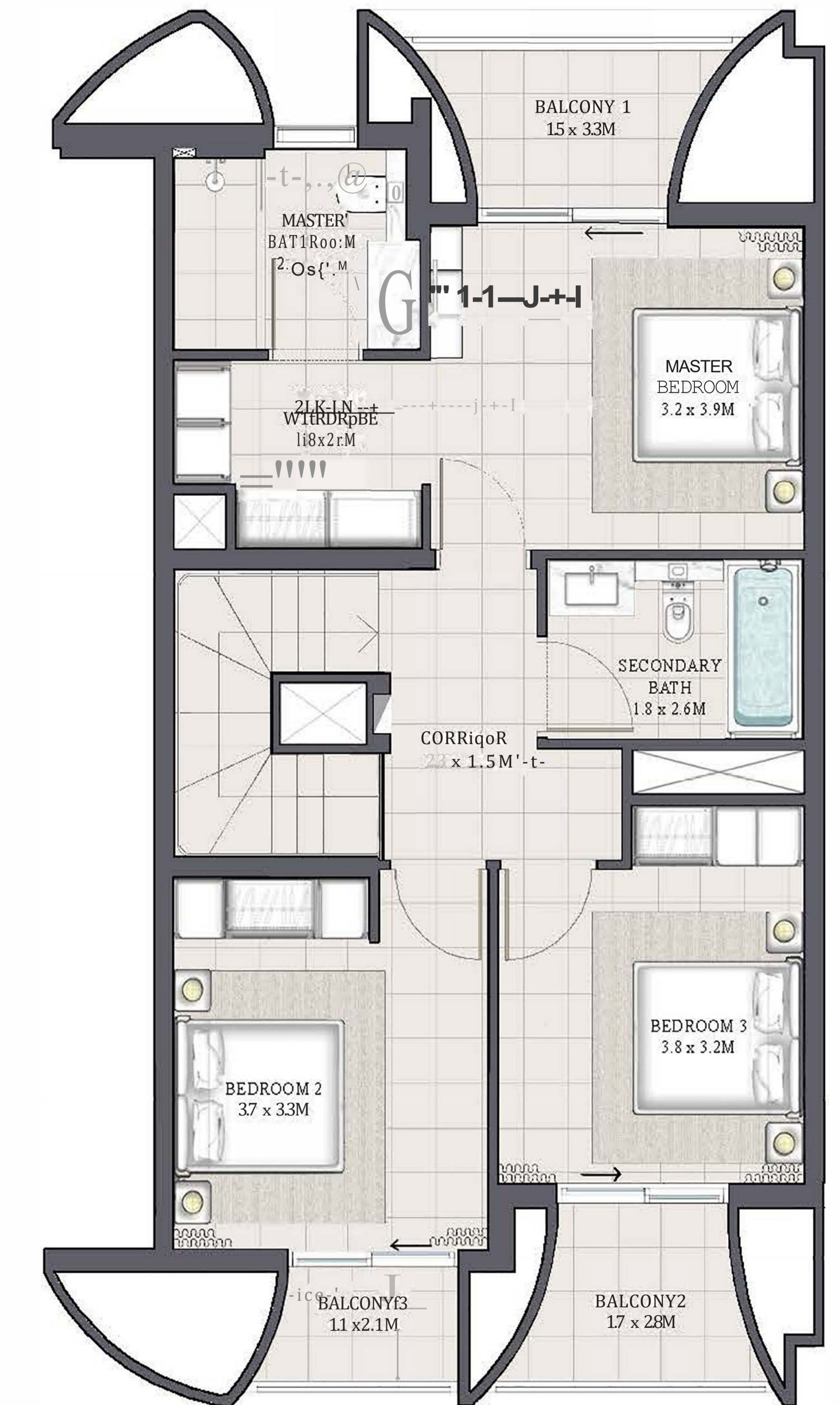

FIRST FLOOR

FLOOR PLAN 1. All dimensions are in imperial and metric, and measured from finish to finish excluding construction tolerances. 2. All materials, dimensions, and drawings are approximate only. 3. Information is subject to change without notice, at developer's absolute discretion. 4. Actual area may vary from the stated area. 5. Drawings not to scale. 6. All images used are for illustrative purposes only and do not represent the actual size, features, specifications, fittings, and furnishings. 7. The developer reserves the right to make revisions / alterations, at it's absolute discretion, without any liability whatsoever.

# ANYA 2

ARABIAN RANCHES III

LUNA

TOWNHOUSE

**3 BEDROOM 3M**

MIRRORED

UNIT	TOTAL AREA	
6PLEX - TH04	1899.07 SQFT	176.43 SQM

## KEY PLAN

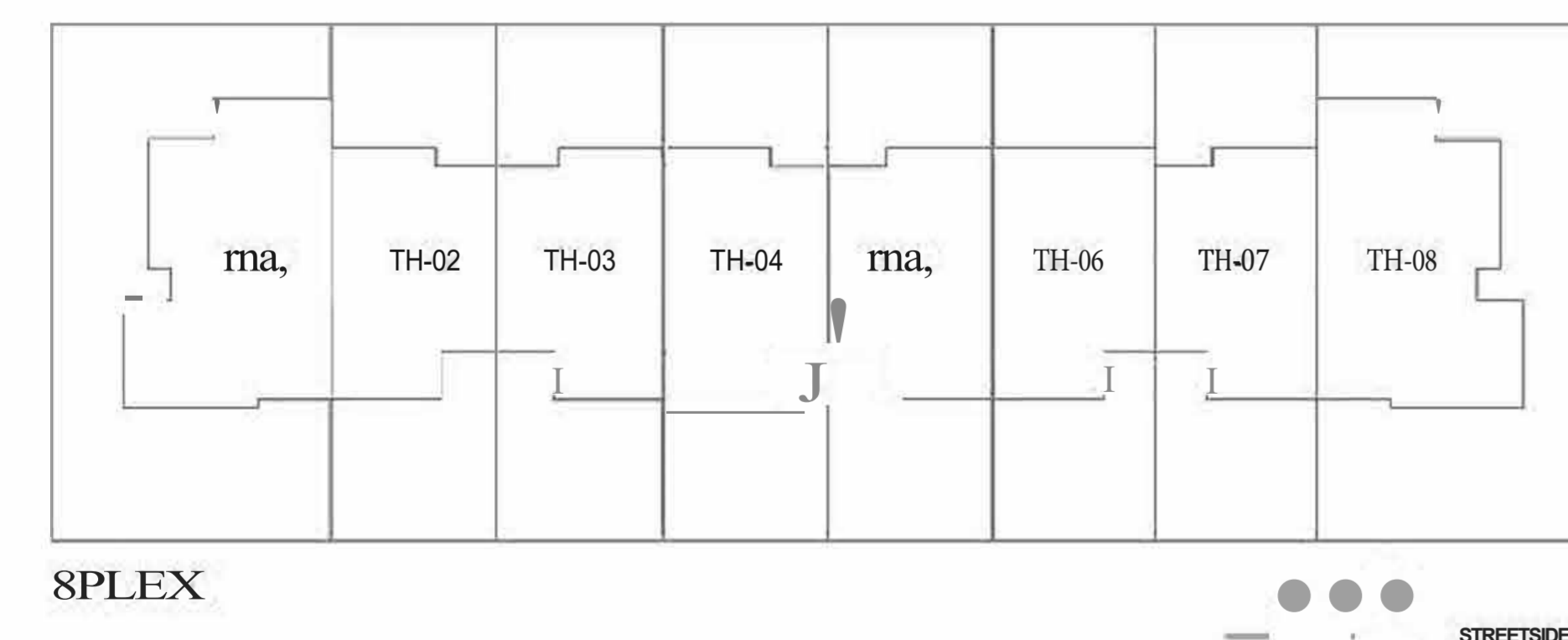
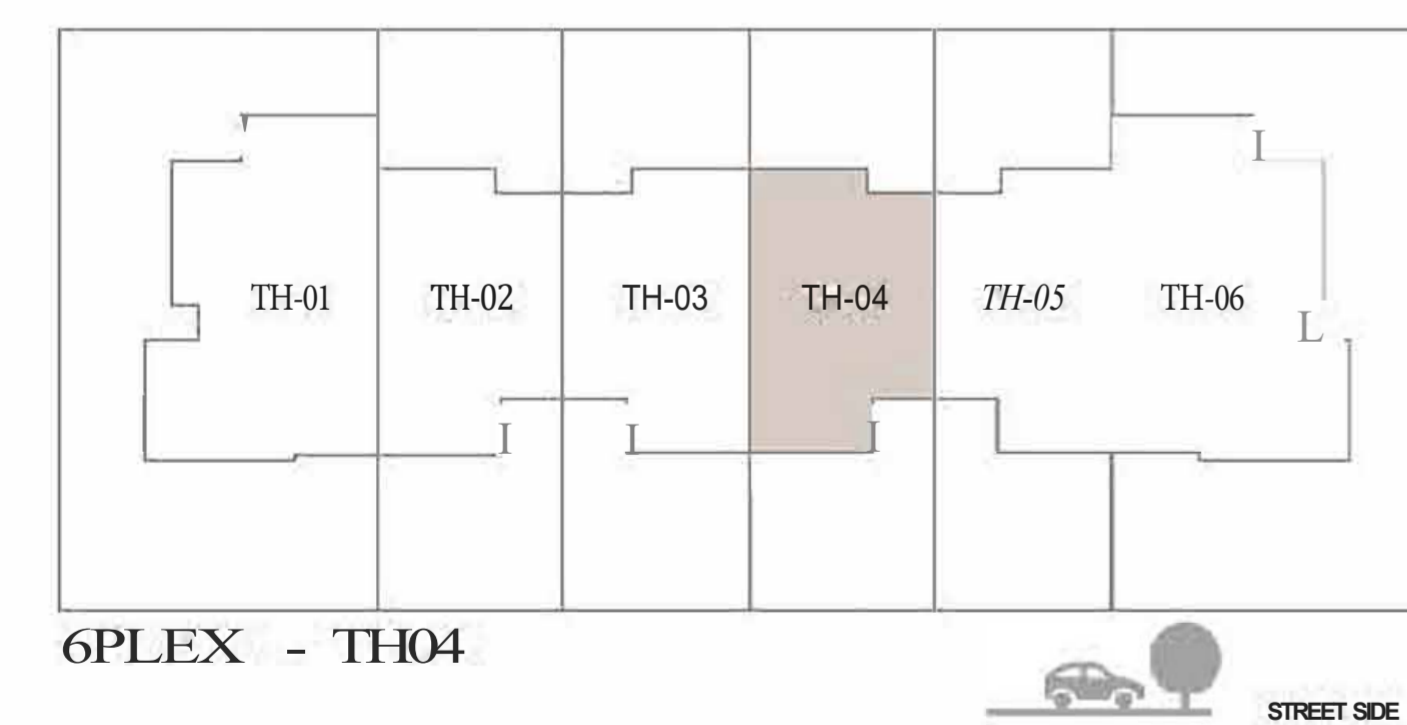
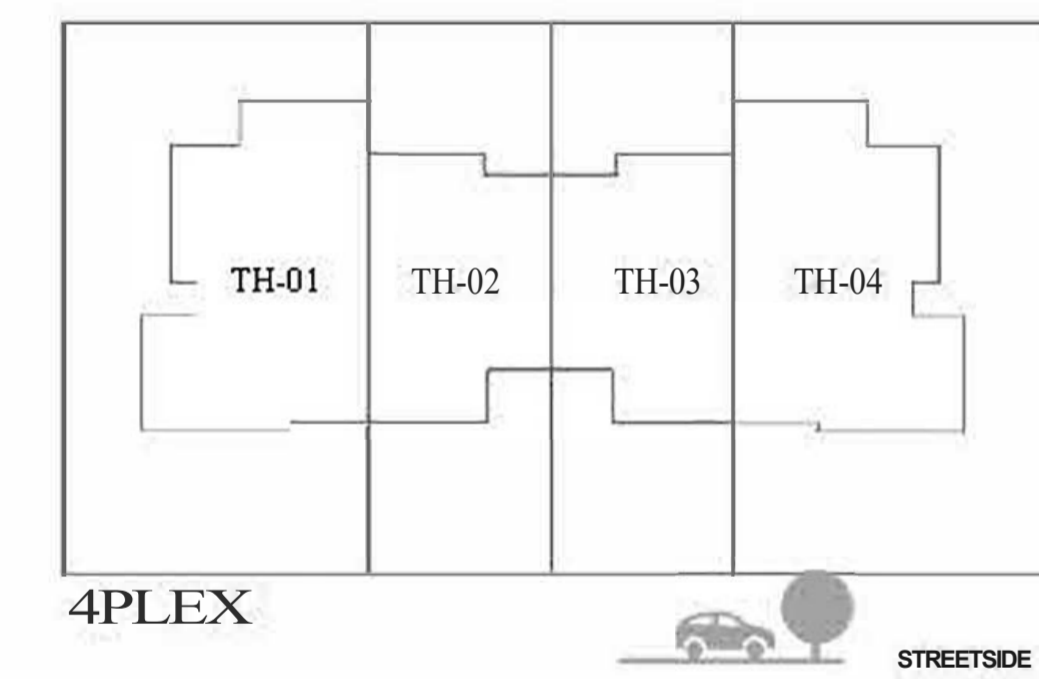

GROUND FLOOR



FIRST FLOOR

FLOOR PLAN 1. All dimensions are in imperial and metric, and measured from finish to finish excluding construction tolerances. 2. All materials, dimensions, and drawings are approximate only. 3. Information is subject to change without notice, at developer's absolute discretion. 4. Actual area may vary from the stated area. 5. Drawings not to scale. 6. All images used are for illustrative purposes only and do not represent the actual size, features, specifications, fittings, and furnishings. 7. The developer reserves the right to make revisions / alterations, at it's absolute discretion, without any liability whatsoever.



# ANYA 2

ARABIAN RANCHES III

LUNA

TOWNHOUSE

**3 BEDROOM 4**

UNIT	TOTAL AREA	
8PLEX - TH03	1899.61 SQFT	176.48 SQM

## KEY PLAN

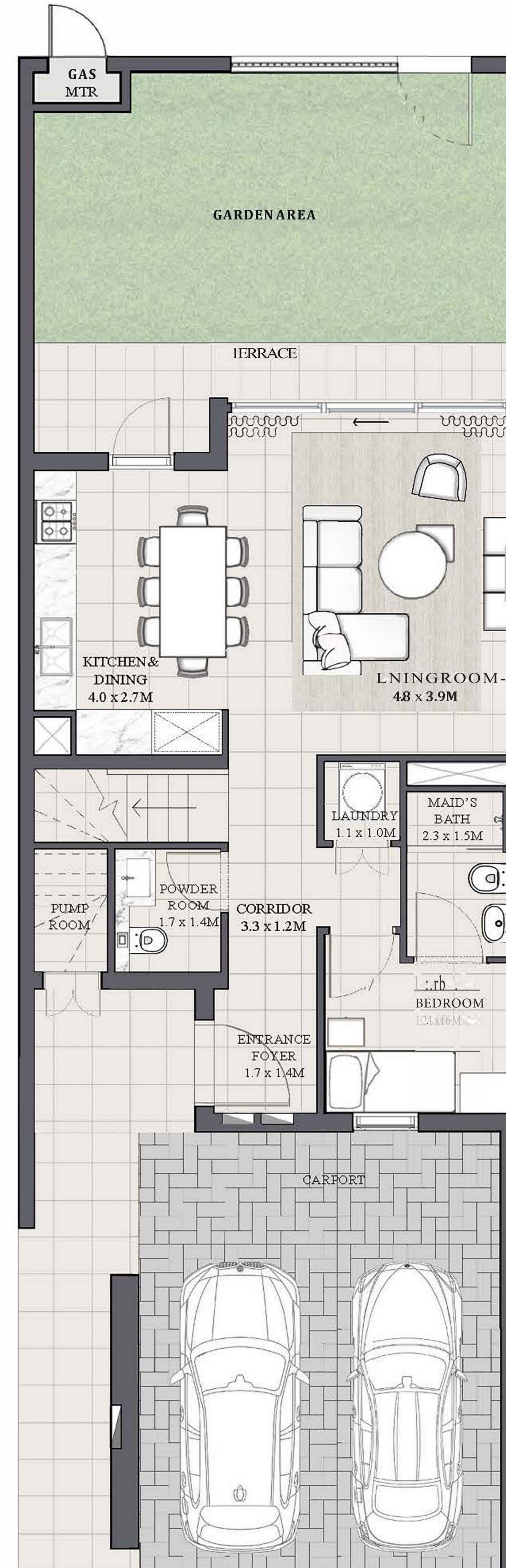
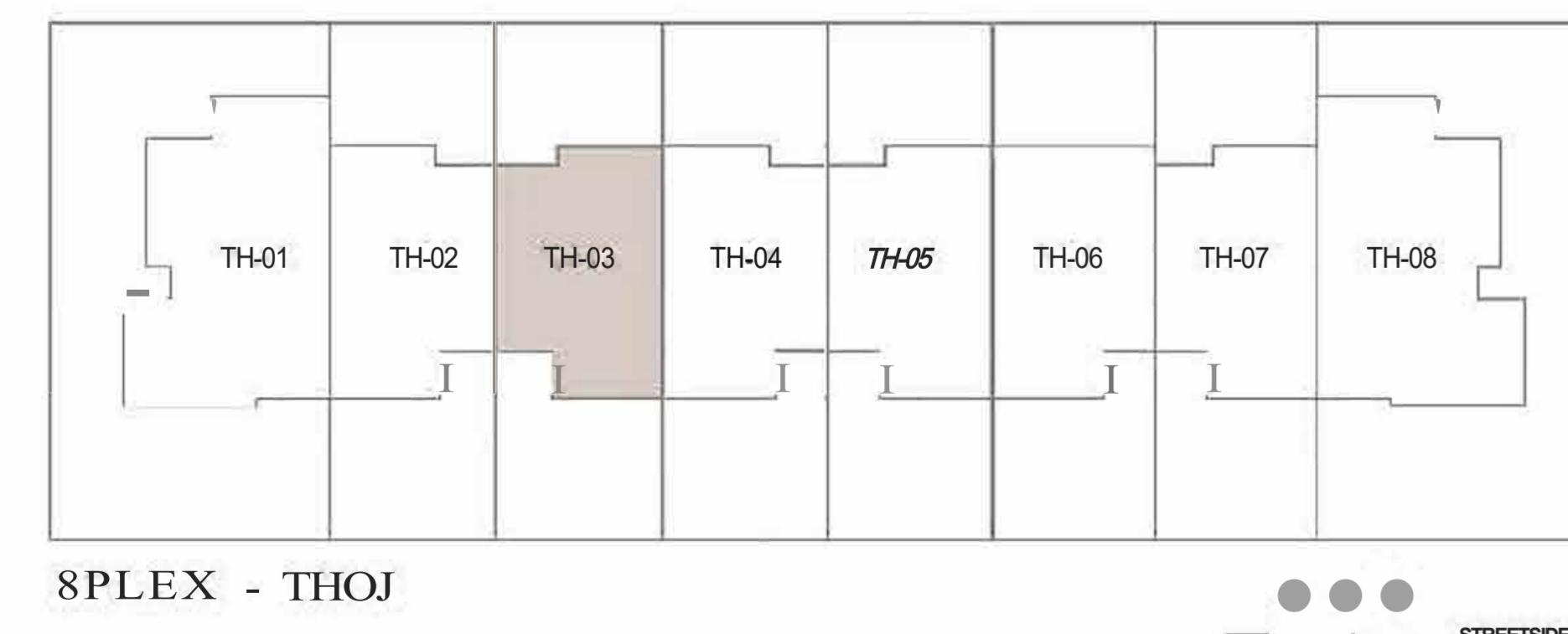
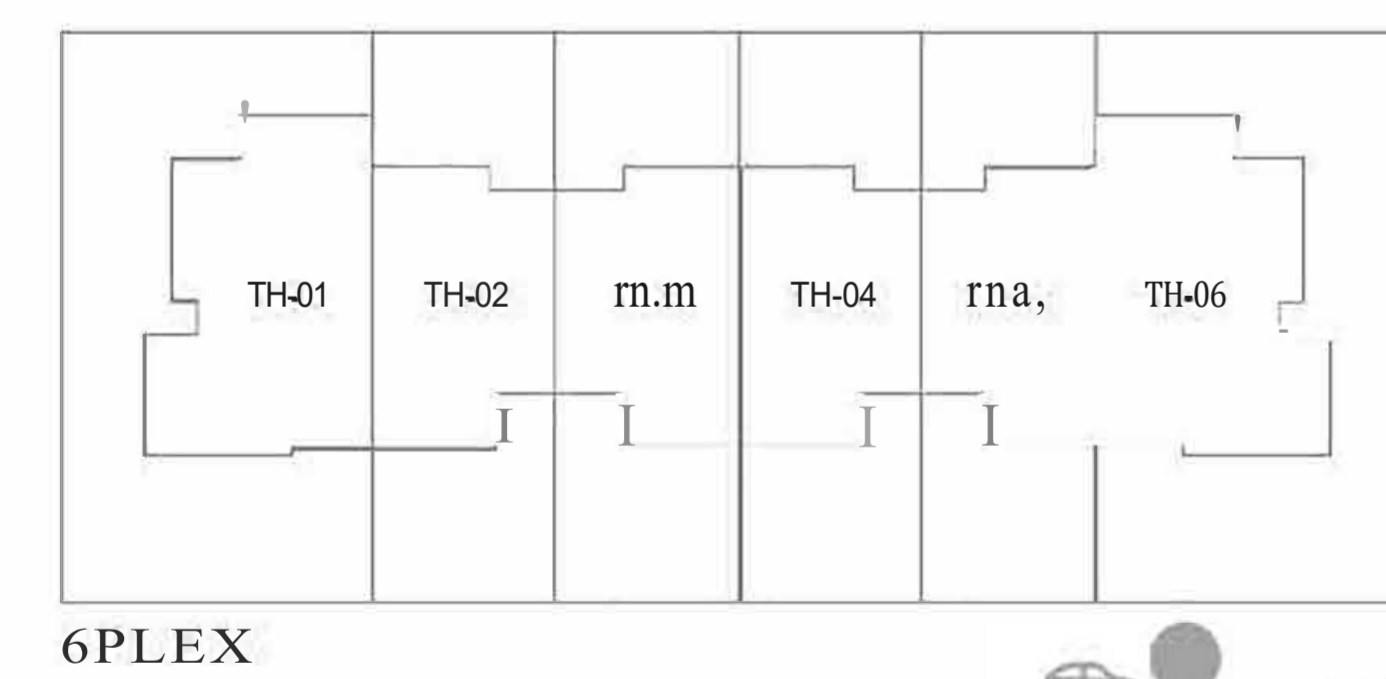
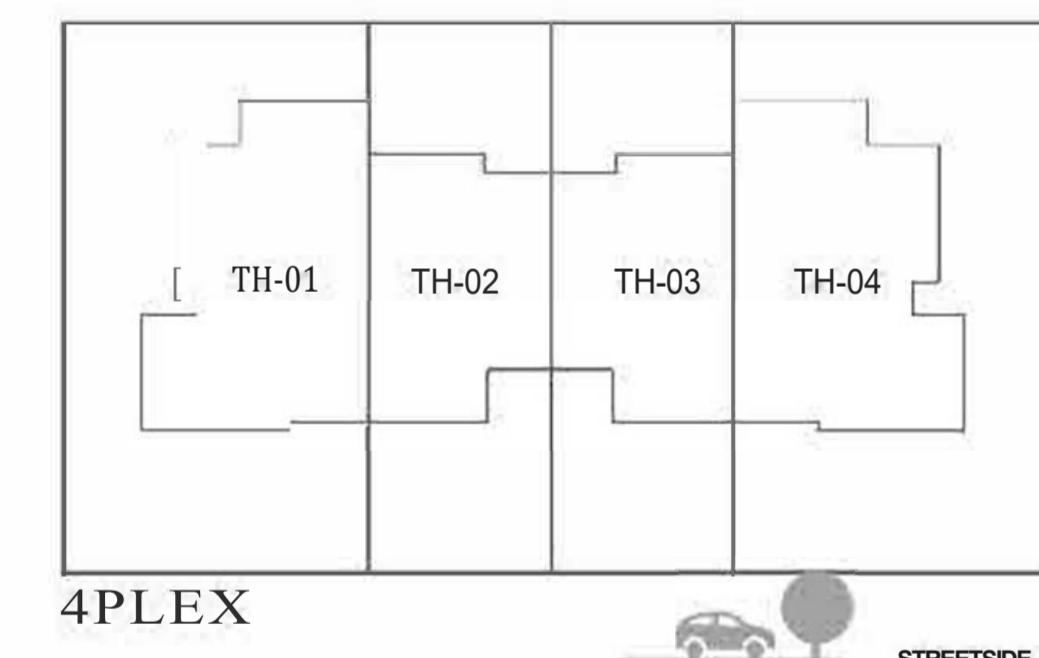

GROUND FLOOR

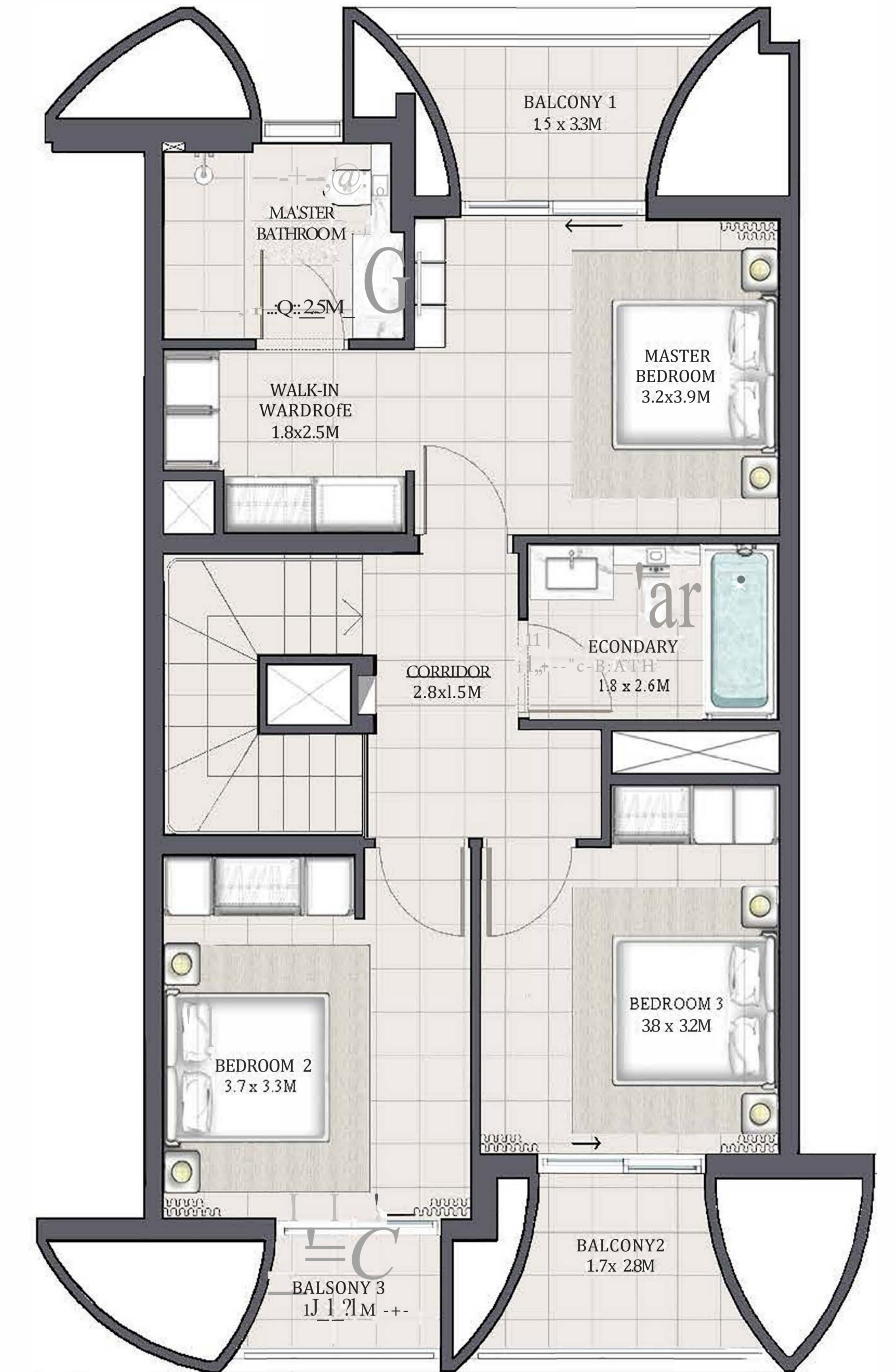

FIRST FLOOR

FLOOR PLAN 1. All dimensions are in imperial and metric, and measured from finish to finish excluding construction tolerances. 2. All materials, dimensions, and drawings are approximate only. 3. Information is subject to change without notice, at developer's absolute discretion. 4. Actual area may vary from the stated area. 5. Drawings not to scale. 6. All images used are for illustrative purposes only and do not represent the actual size, features, specifications, fittings, and furnishings. 7. The developer reserves the right to make revisions / alterations, at it's absolute discretion, without any liability whatsoever.

# ANYA 2

ARABIAN RANCHES III

LUNA

TOWNHOUSE

**3 BEDROOM 4M**

MIRRORED

UNIT	TOTAL AREA	
8PLEX - TH06	1899.61 SQFT	176.48 SQM

## KEY PLAN

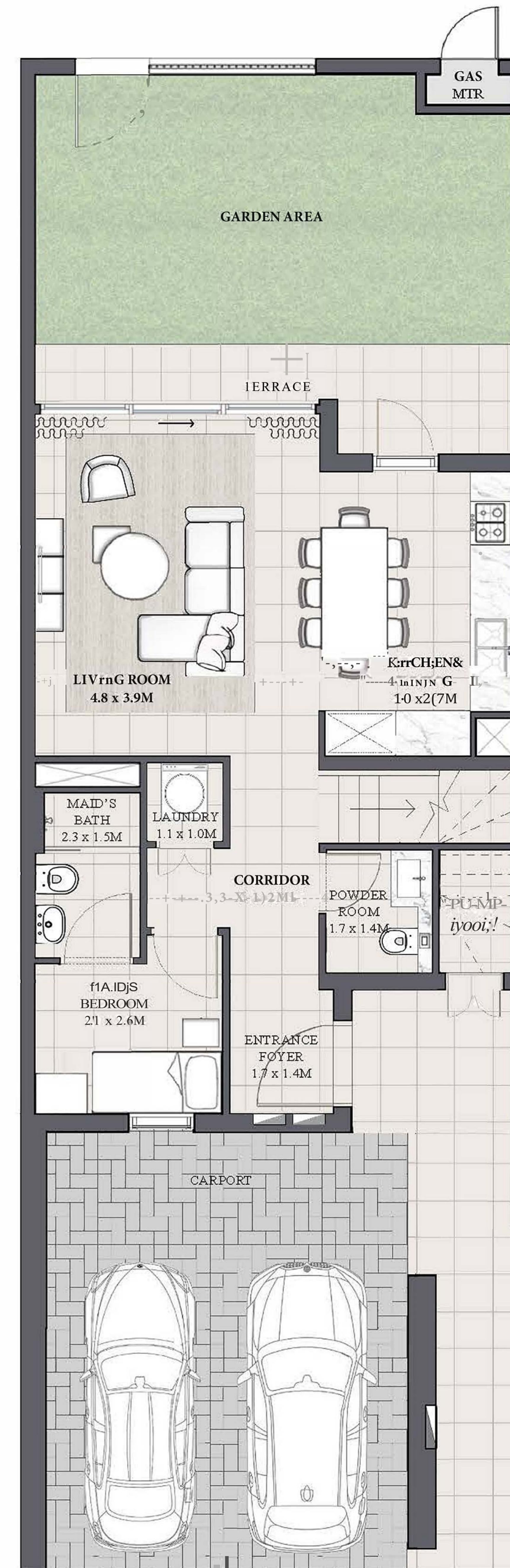
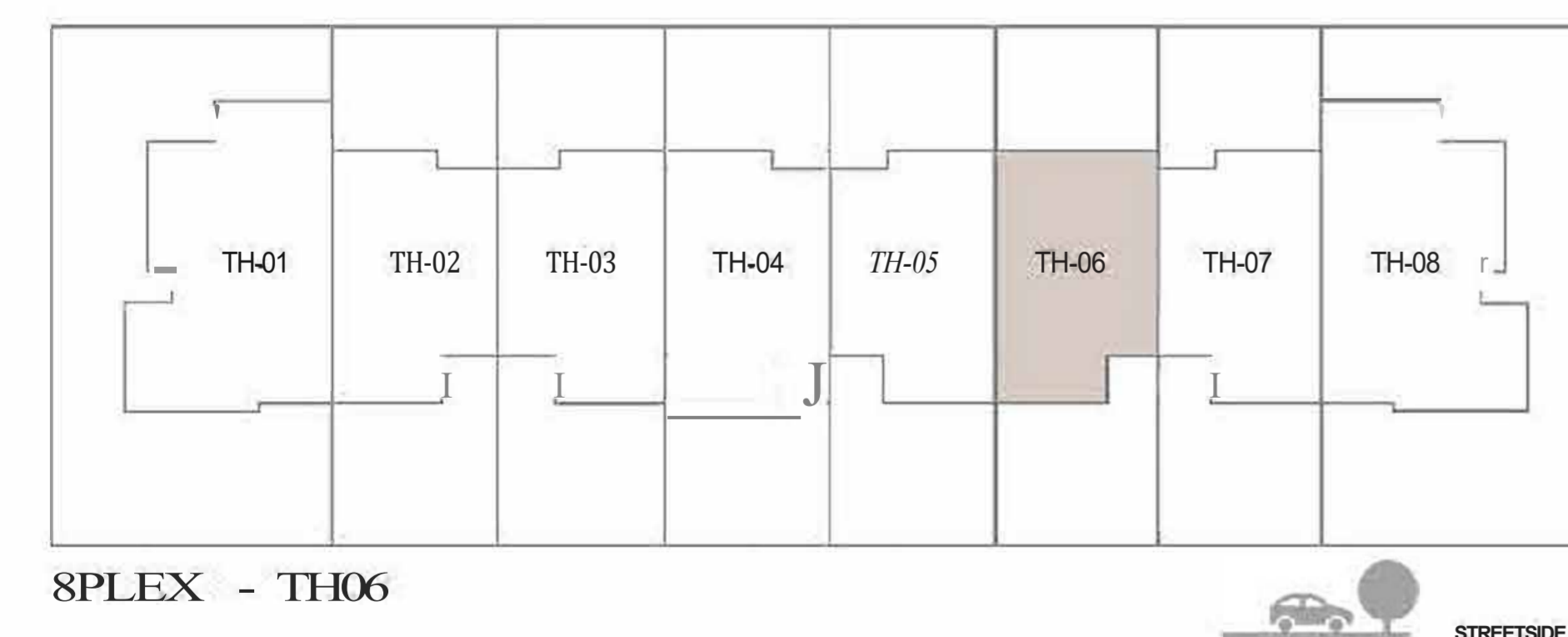
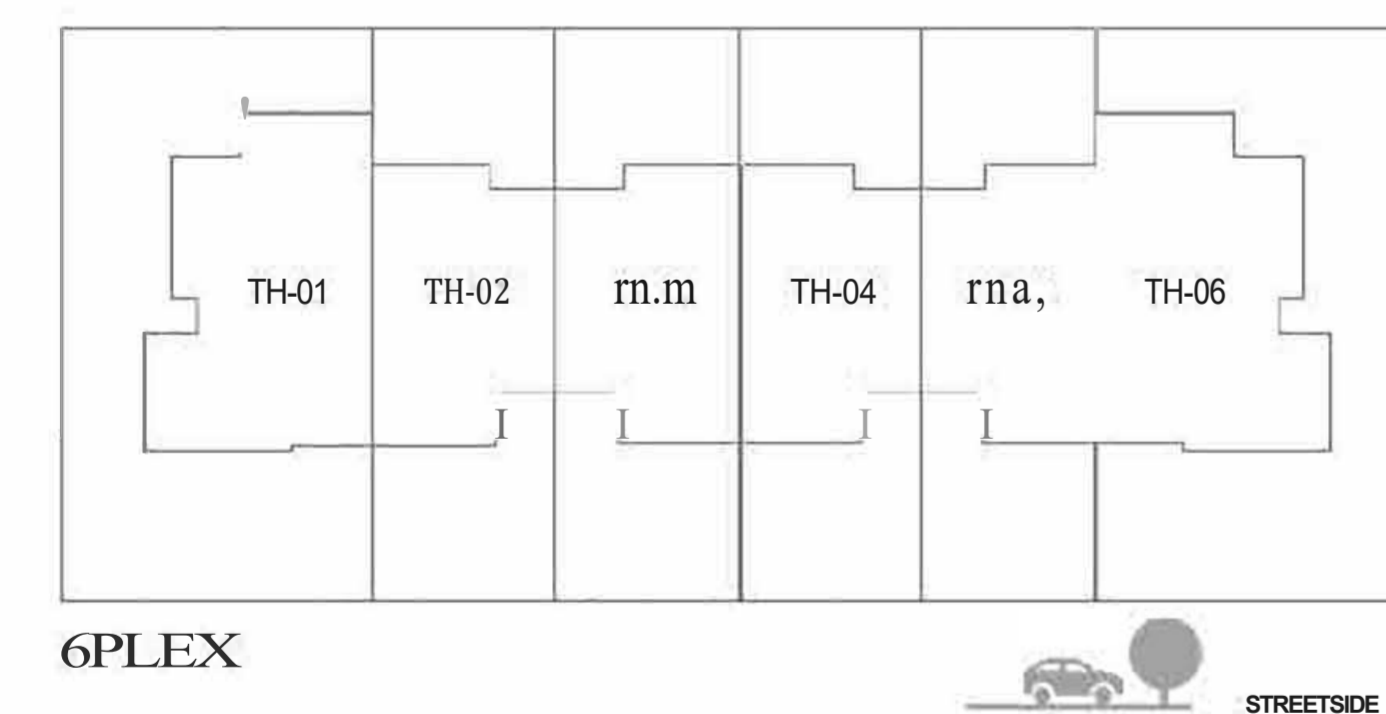
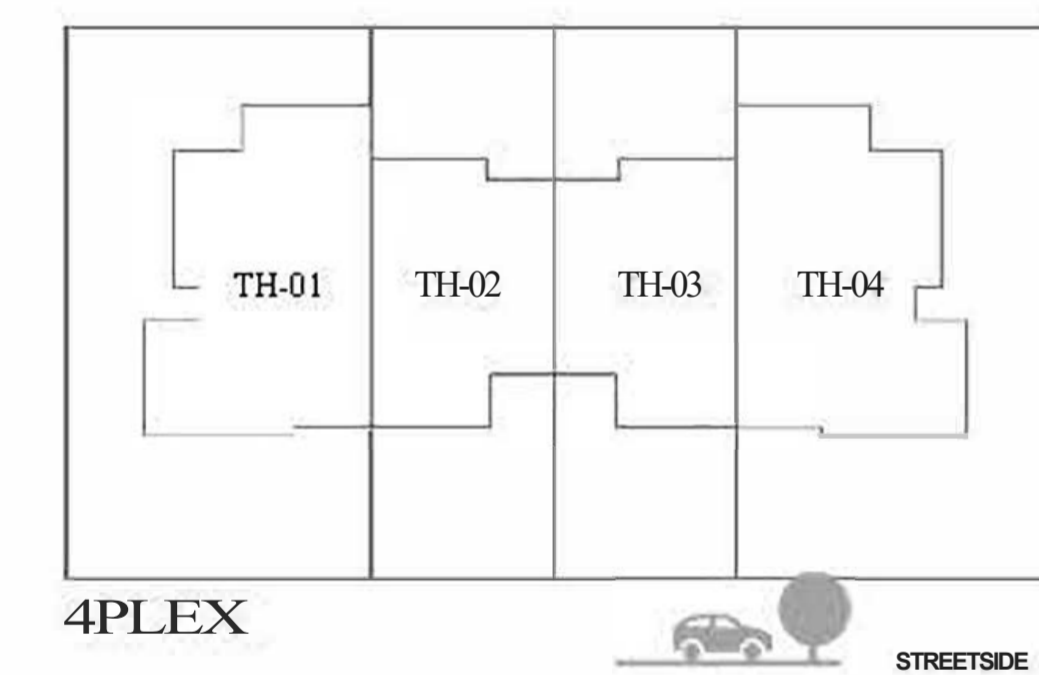

GROUND FLOOR

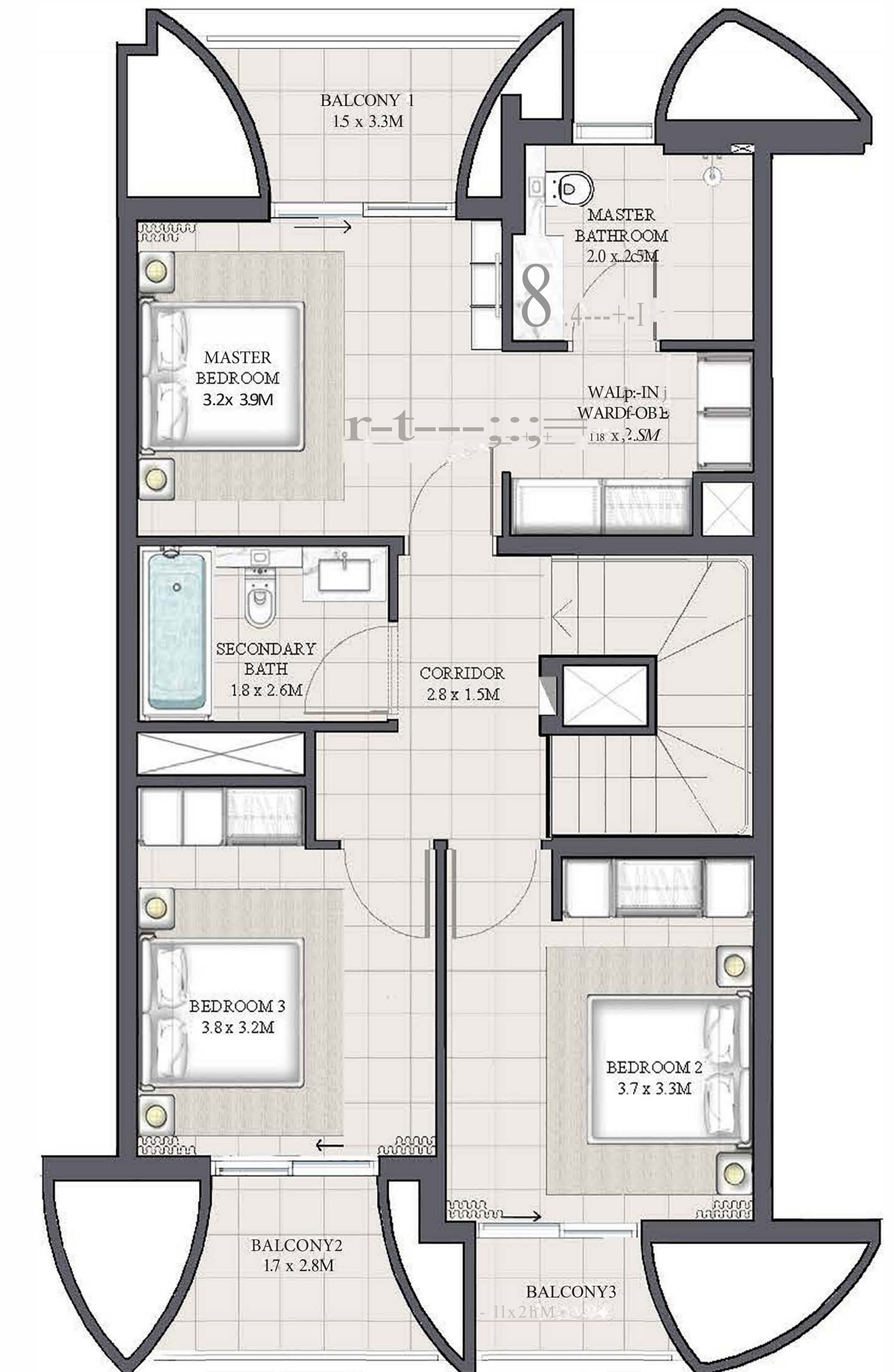

FIRST FLOOR

FLOOR PLAN 1. All dimensions are in imperial and metric, and measured from finish to finish excluding construction tolerances. 2. All materials, dimensions, and drawings are approximate only. 3. Information is subject to change without notice, at developer's absolute discretion. 4. Actual area may vary from the stated area. 5. Drawings not to scale. 6. All images used are for illustrative purposes only and do not represent the actual size, features, specifications, fittings, and furnishings. 7. The developer reserves the right to make revisions / alterations, at it's absolute discretion, without any liability whatsoever.

# ANYA 2

ARABIAN RANCHES III

LUNA

TOWNHOUSE

3 BEDROOM 5

UNIT	TOTAL AREA	
8PLEX - TH04	1899.29 SQFT	176.45 SQM

## KEY PLAN

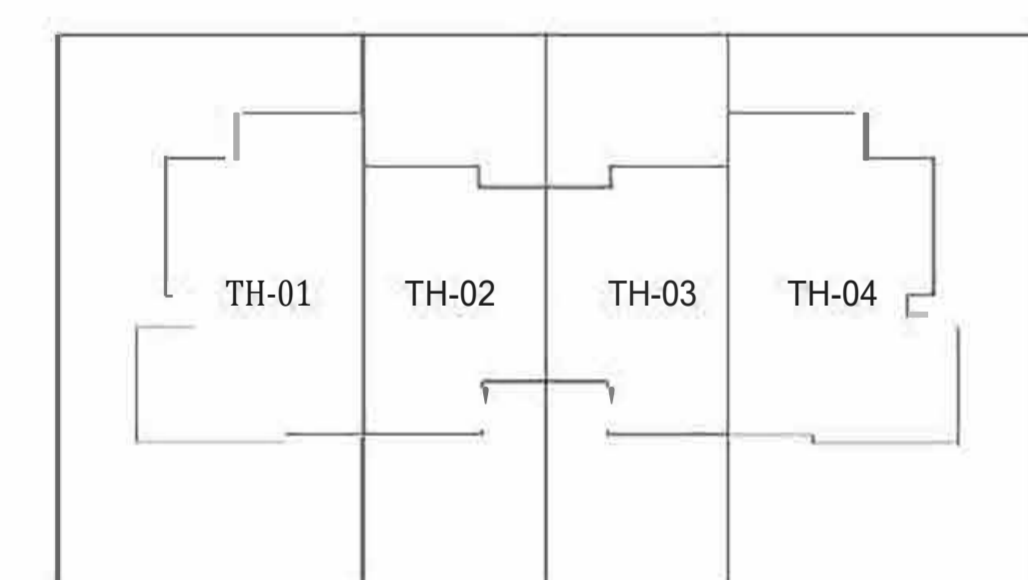

4PLEX

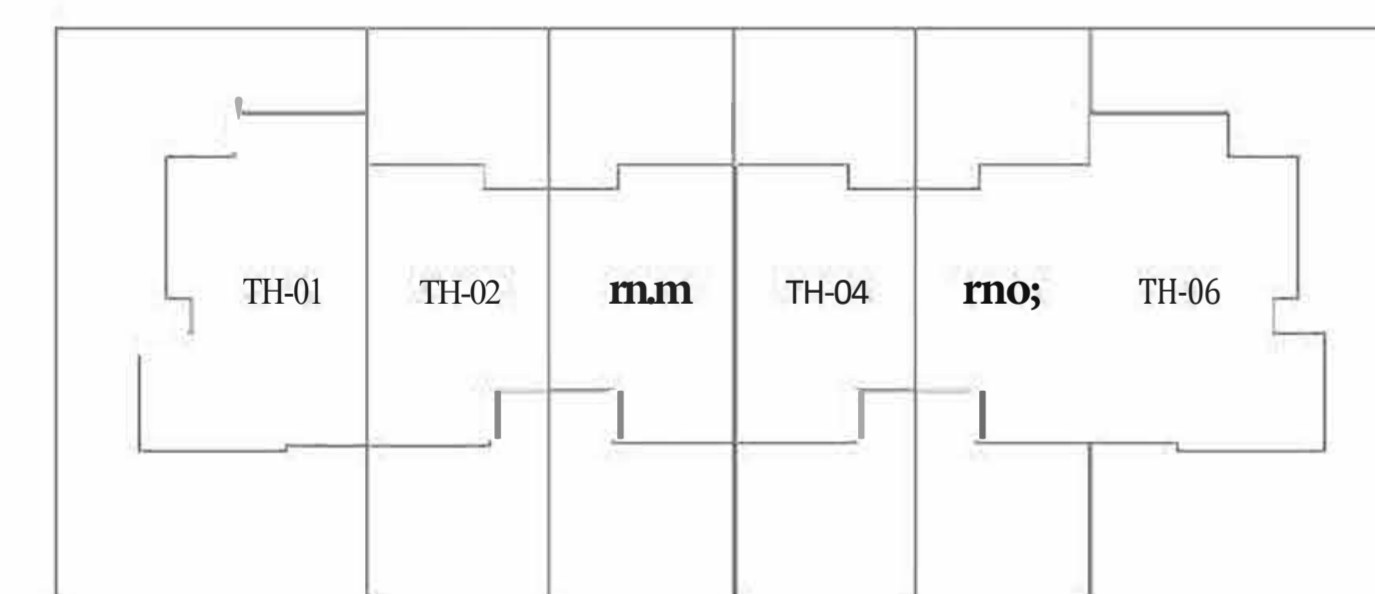

6PLEX

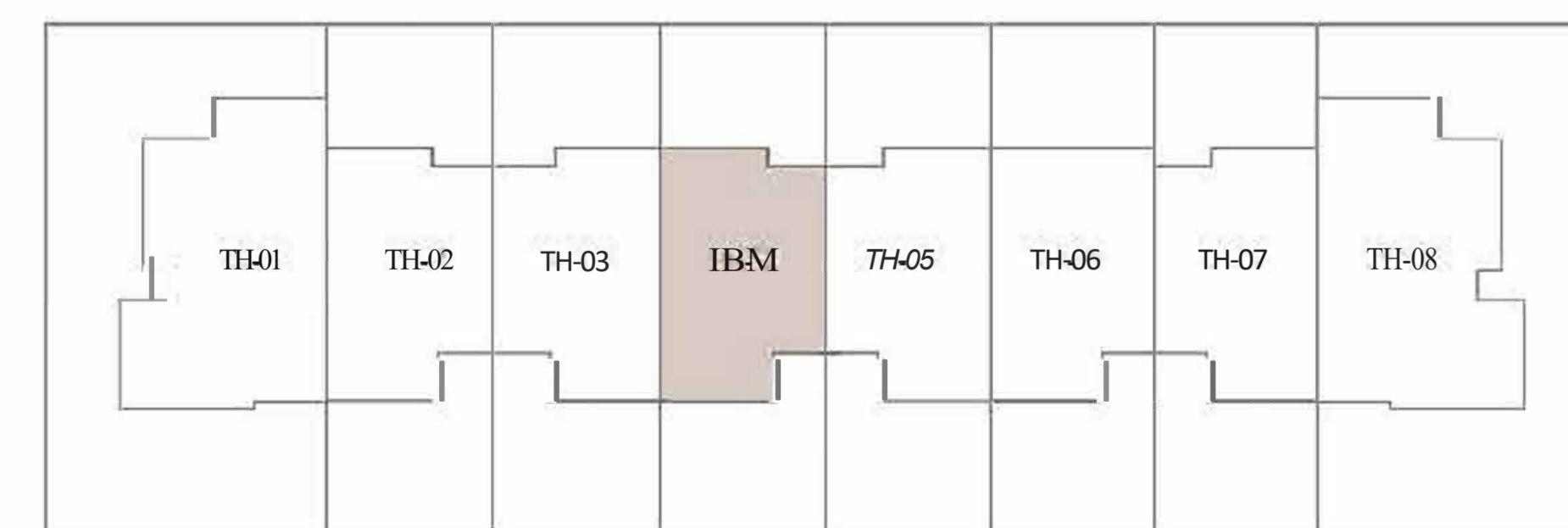

8PLEX - TH04

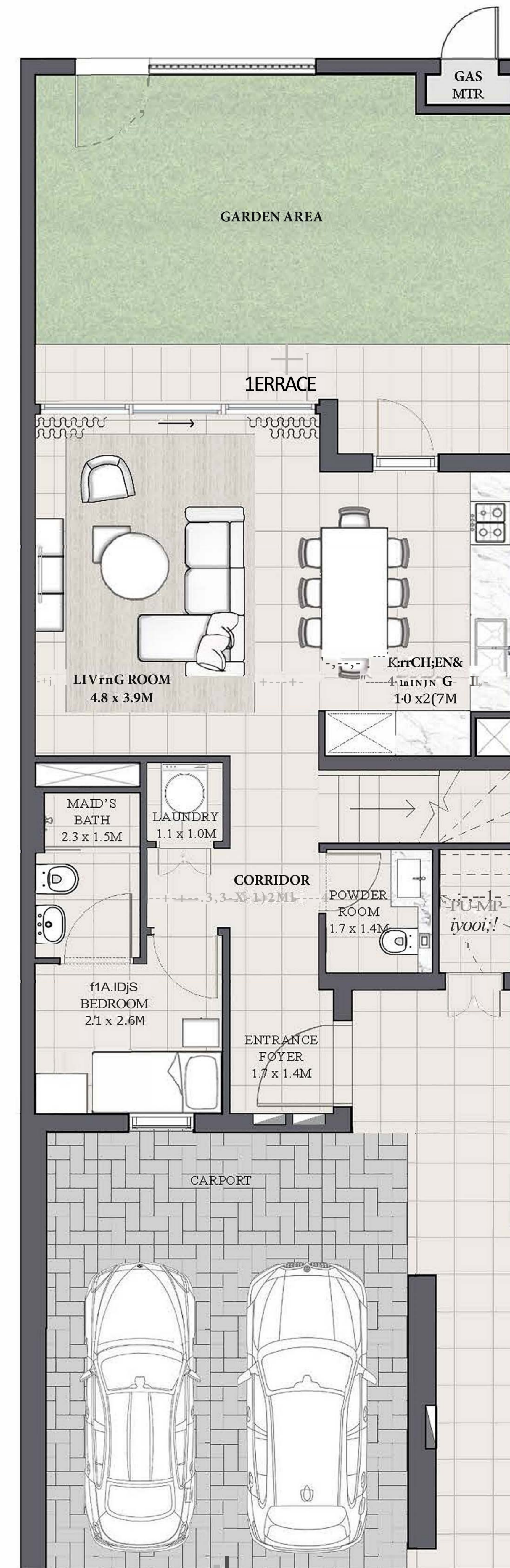

GROUND FLOOR

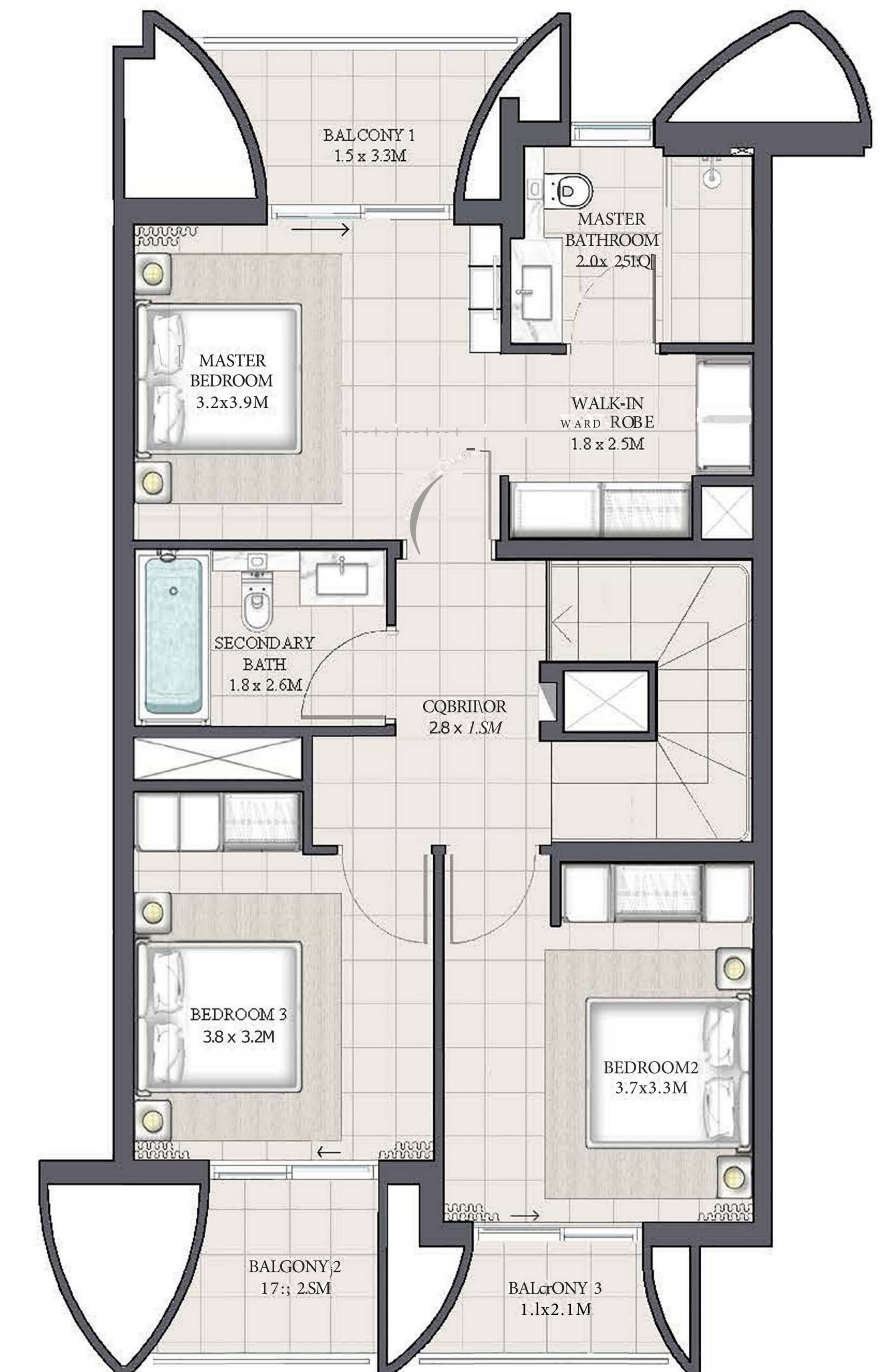

FIRST FLOOR

FLOOR PLAN 1. All dimensions are in imperial and metric, and measured from finish to finish excluding construction tolerances. 2. All materials, dimensions, and drawings are approximate only. 3. Information is subject to change without notice, at developer's absolute discretion. 4. Actual area may vary from the stated area. 5. Drawings not to scale. 6. All images used are for illustrative purposes only and do not represent the actual size, features, specifications, fittings, and furnishings. 7. The developer reserves the right to make revisions / alterations, at it's absolute discretion, without any liability whatsoever.

# ANYA 2

ARABIAN RANCHES III

LUNA

TOWNHOUSE

3 BEDROOM 6

UNIT	TOTAL AREA	
8PLEX - TH05	1899.72 SQFT	176.49 SQM

## KEY PLAN

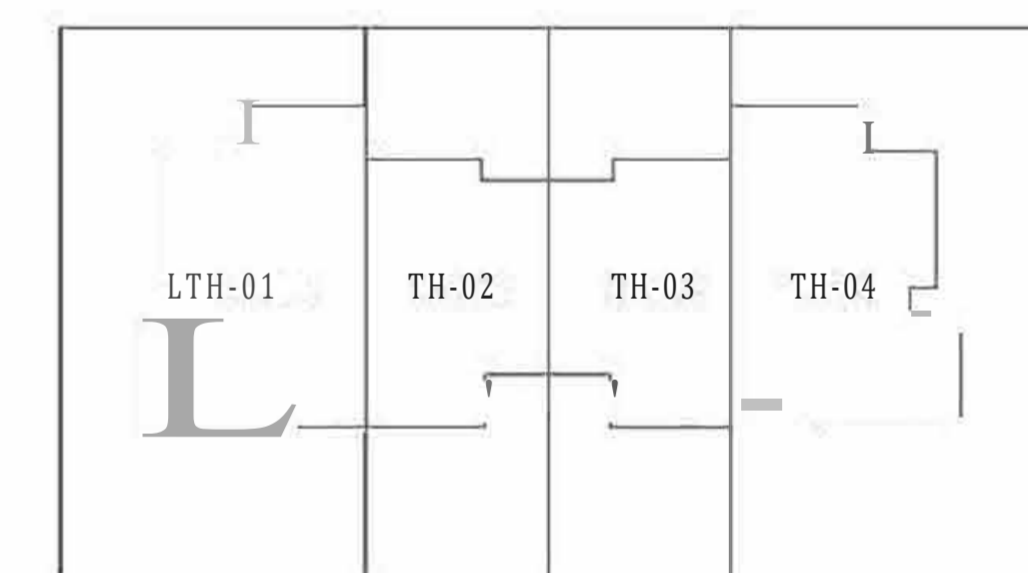

4PLEX

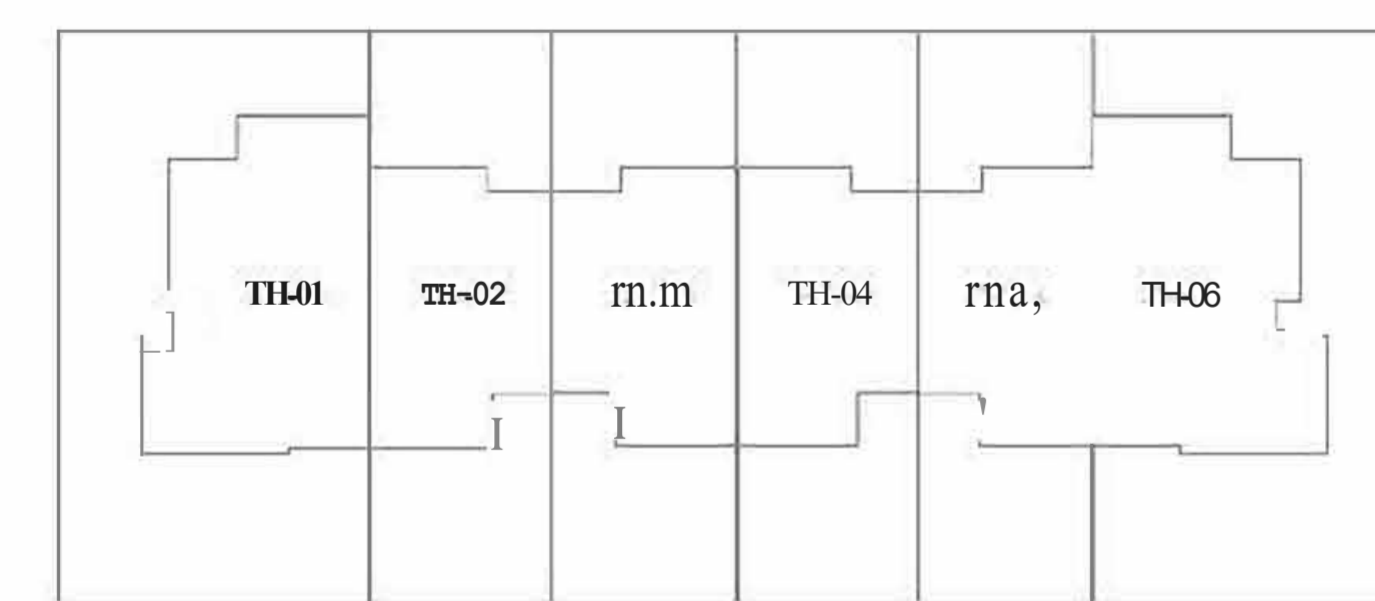

6PLEX

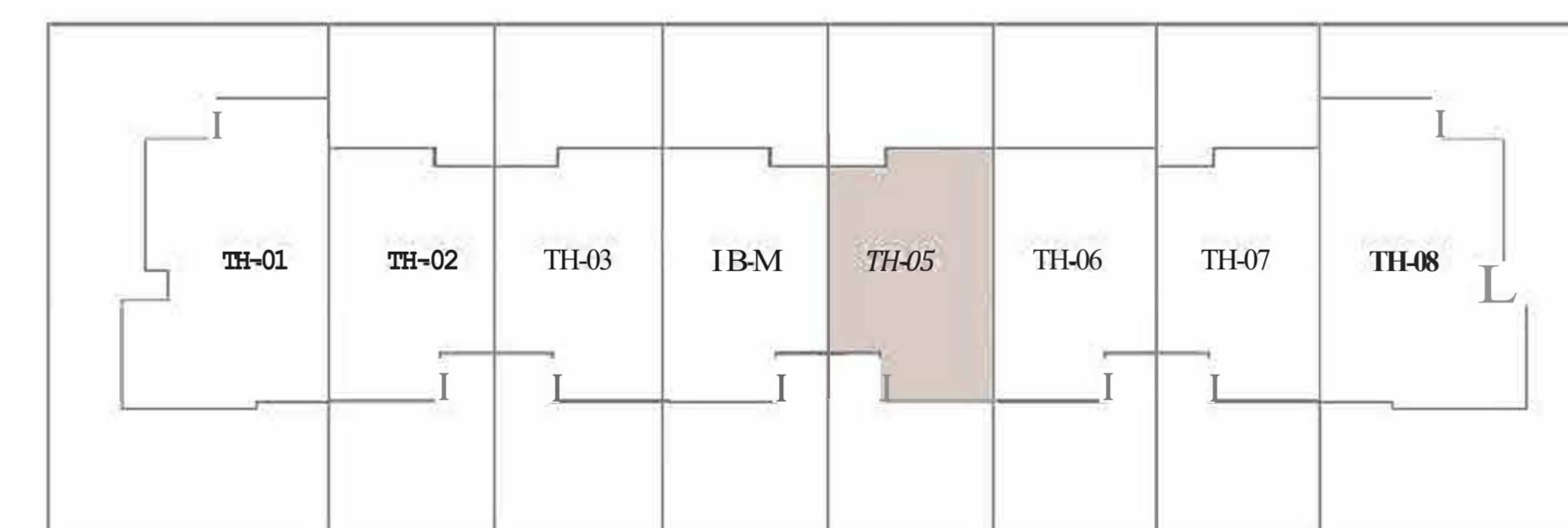

8PLEX - TH05

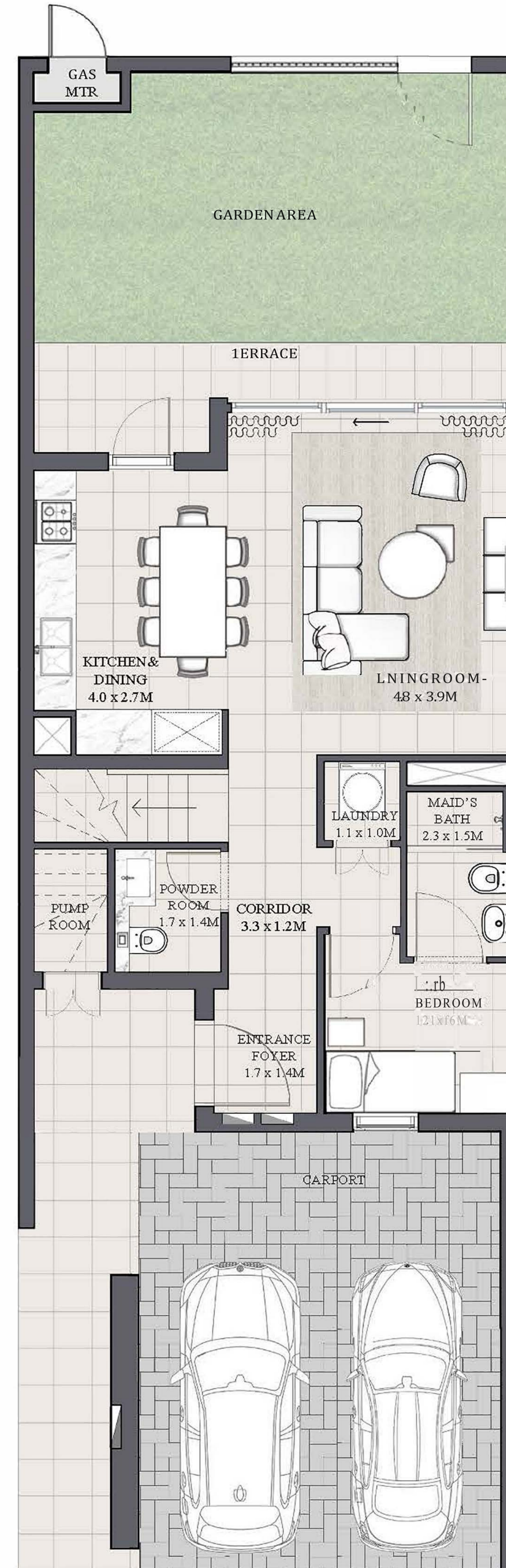

GROUND FLOOR

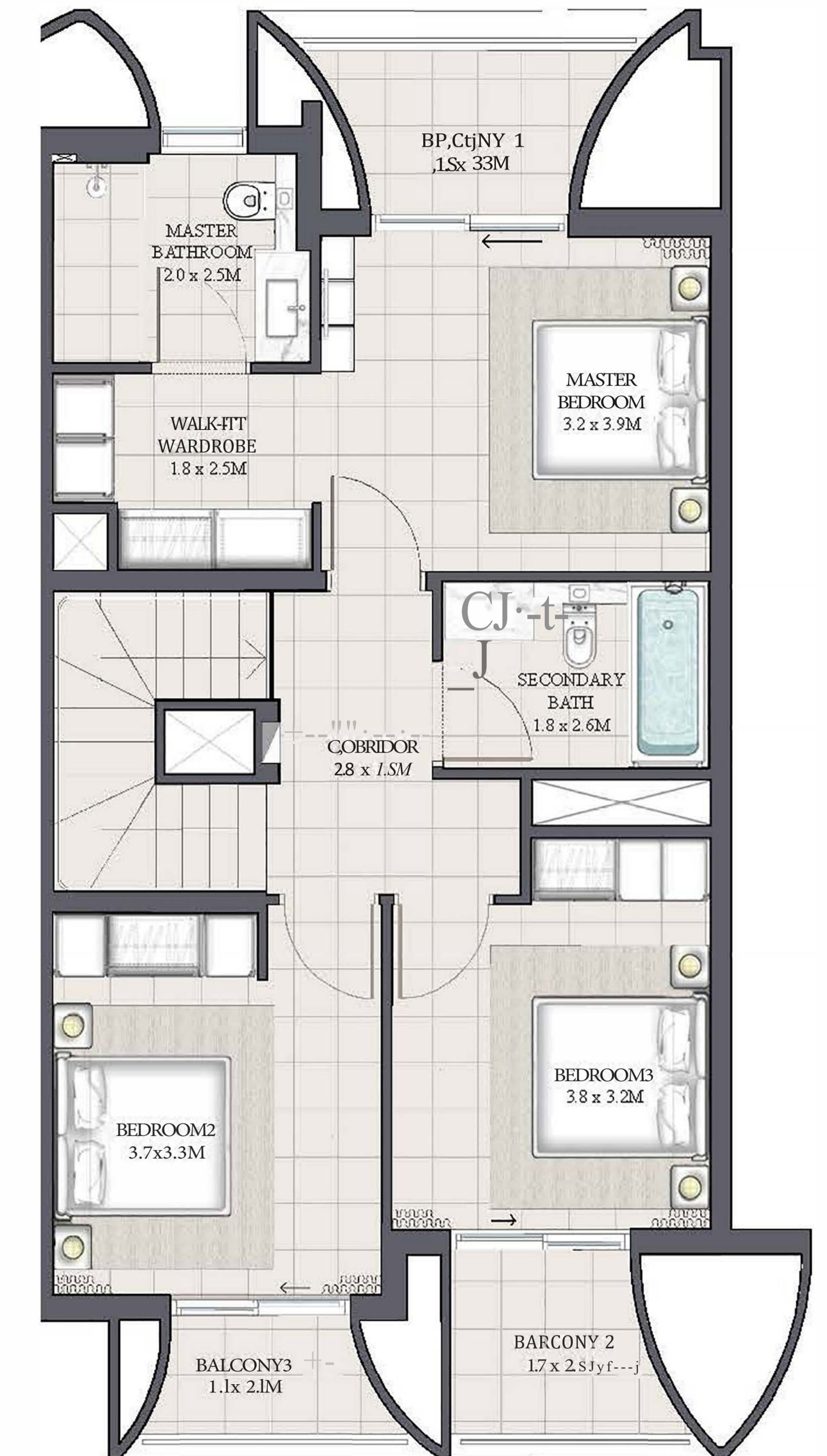

FIRST FLOOR

FLOOR PLAN 1. All dimensions are in imperial and metric, and measured from finish to finish excluding construction tolerances. 2. All materials, dimensions, and drawings are approximate only. 3. Information is subject to change without notice, at developer's absolute discretion. 4. Actual area may vary from the stated area. 5. Drawings not to scale. 6. All images used are for illustrative purposes only and do not represent the actual size, features, specifications, fittings, and furnishings. 7. The developer reserves the right to make revisions / alterations, at it's absolute discretion, without any liability whatsoever.

# ANYA 2

ARABIAN RANCHES III

## ARIA TOWNHOUSE 4 BEDROOM 1

UNIT	TOTAL AREA	
4PL EX - TH01		
6PLEX - TH01	2462.67 SQFT	228.79 SQM
8PLEX - TH01		

### KEY PLAN

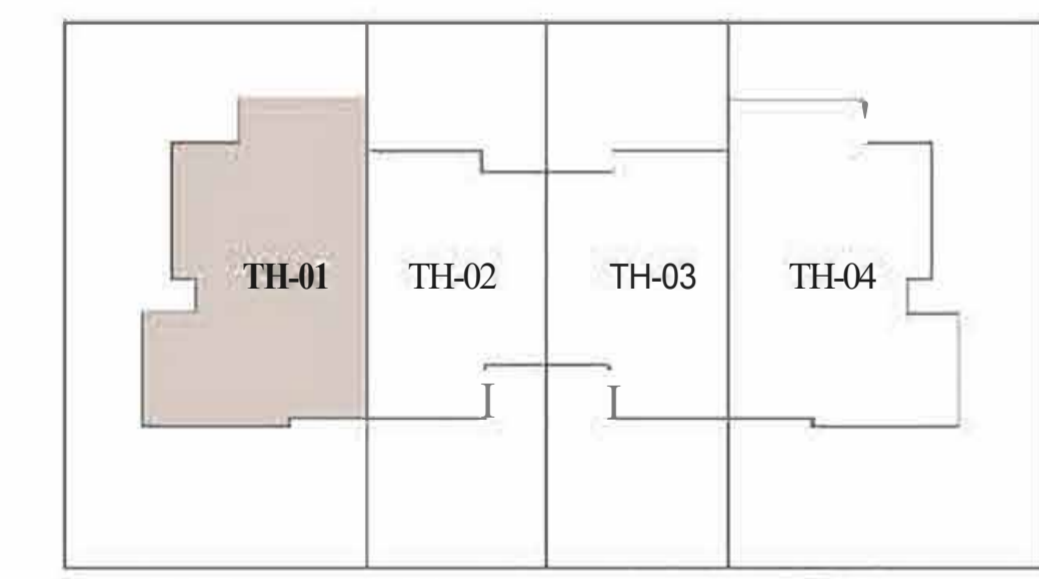

4PLEX - TH01

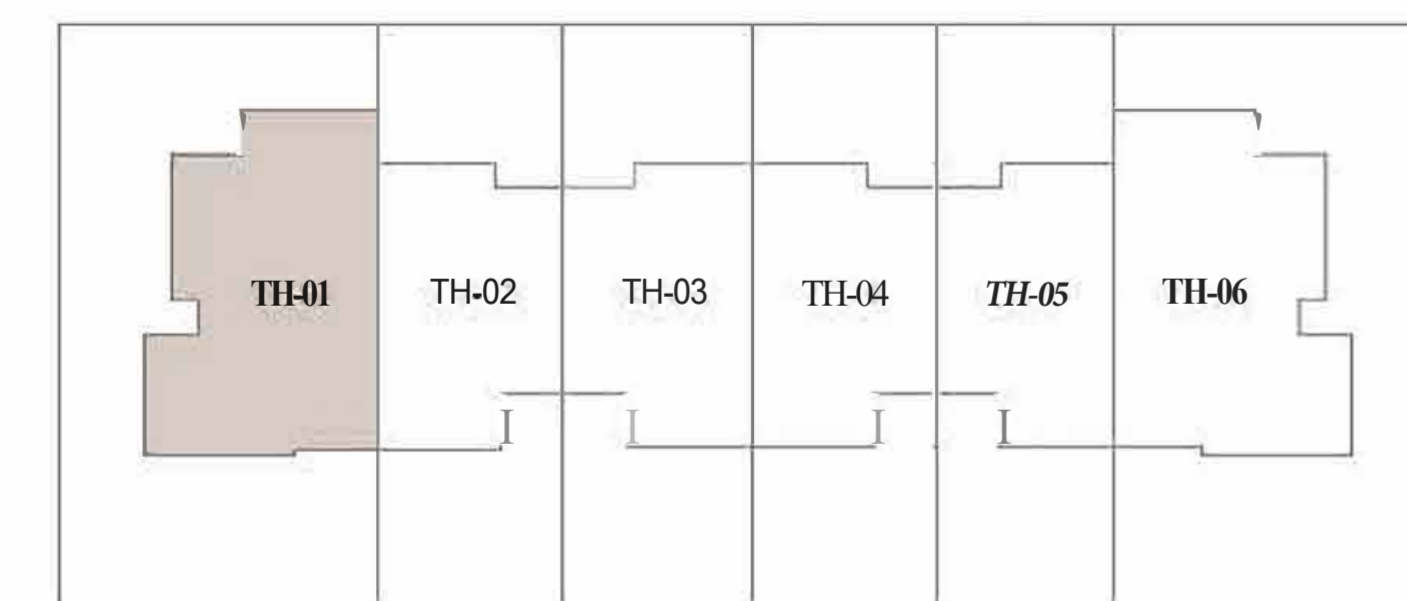

6PLEX - TH01

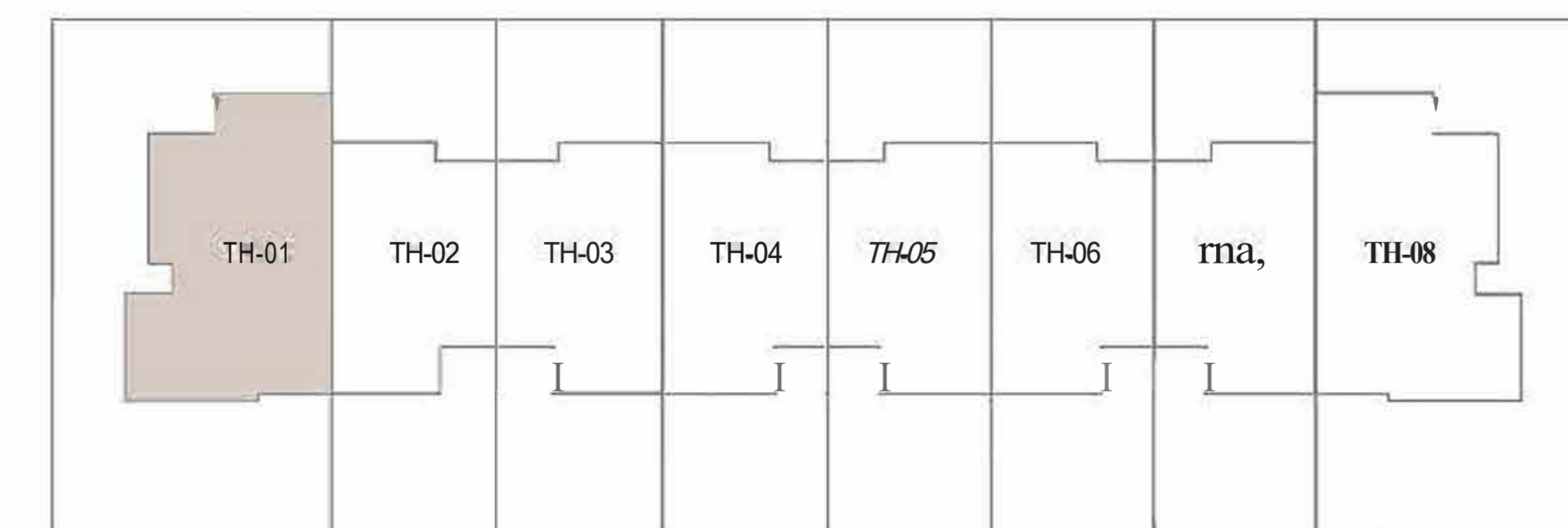

8PLEX - TH01

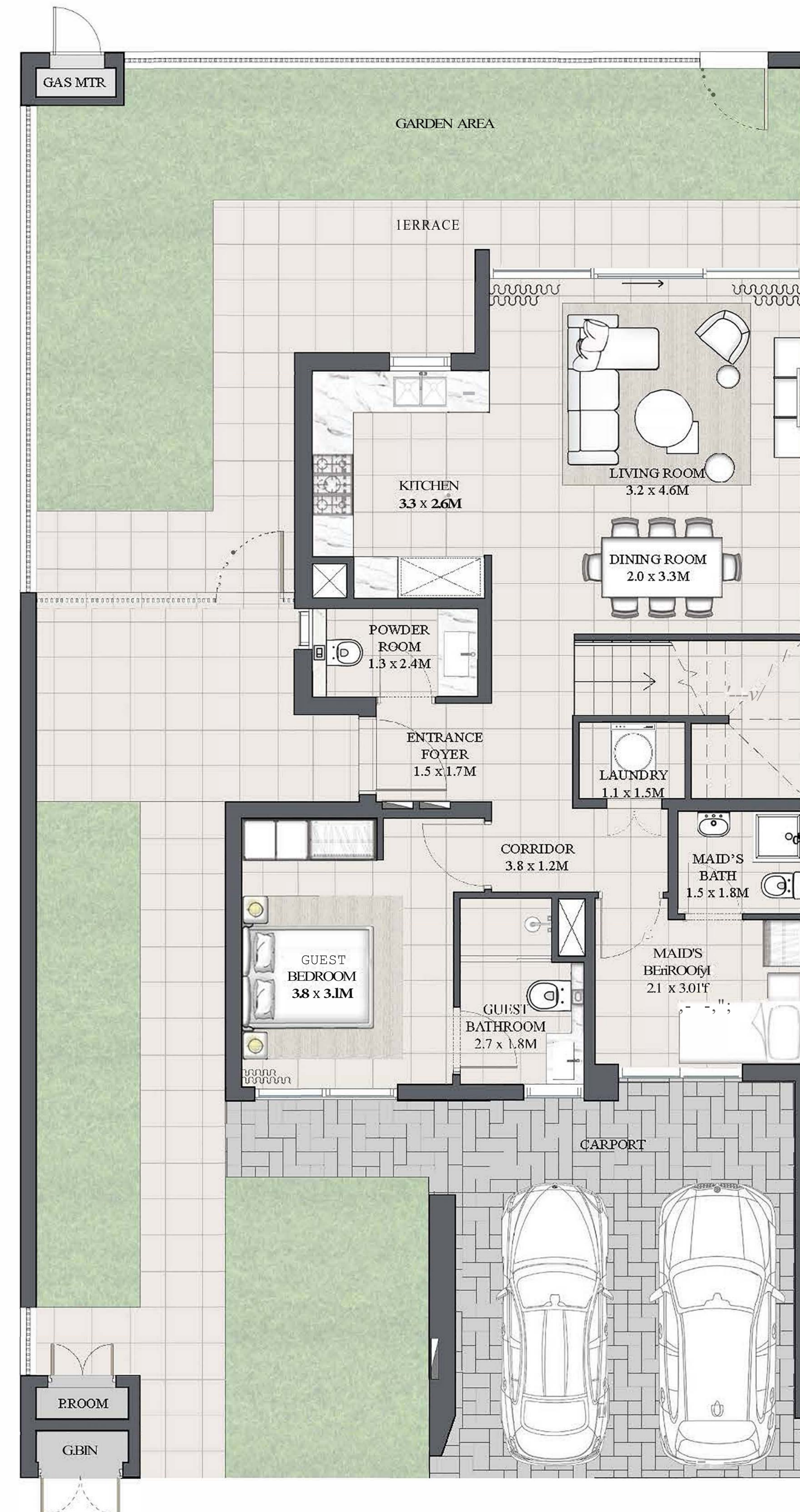

GROUND FLOOR

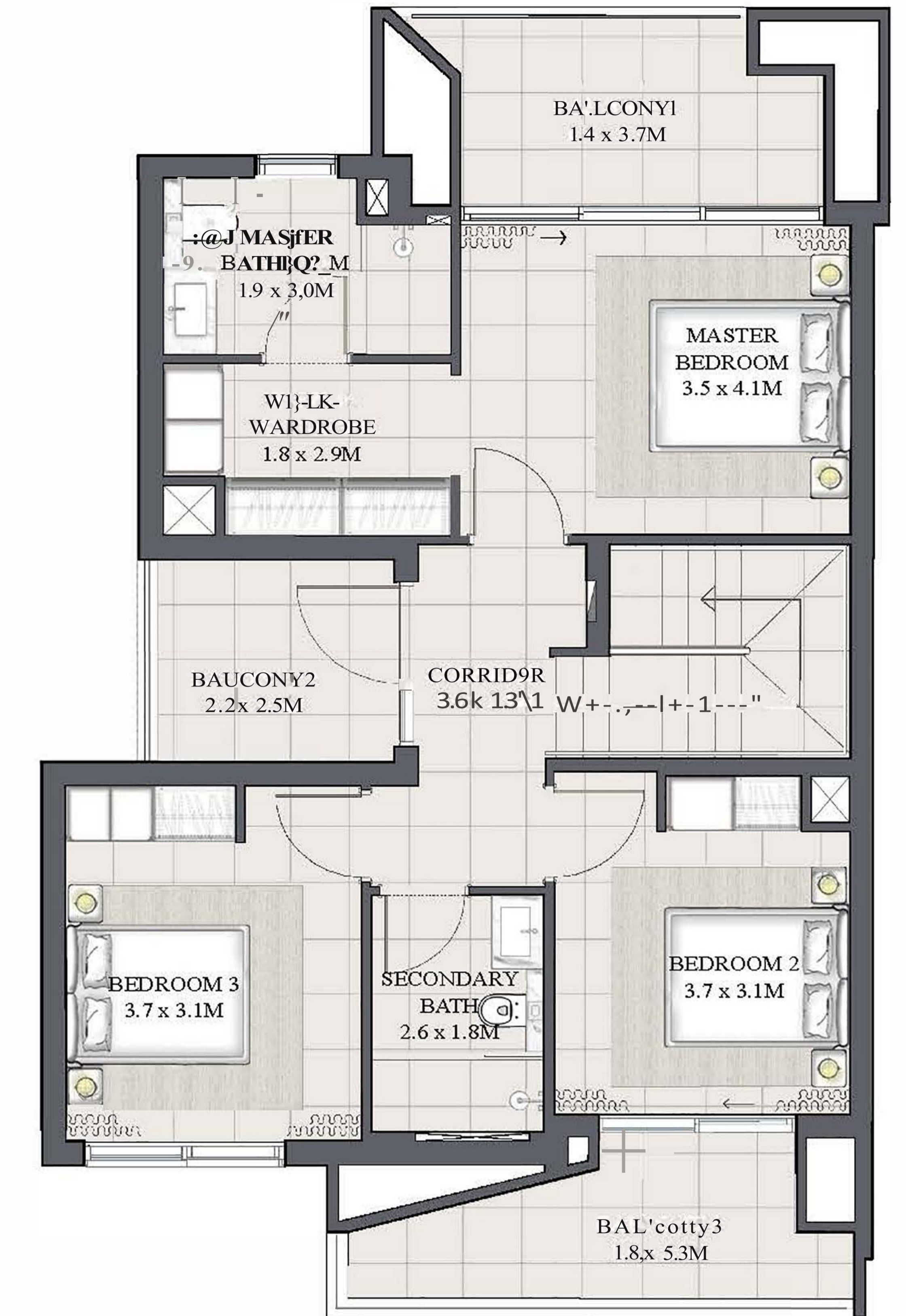

FIRST FLOOR

FLOOR PLAN 1. All dimensions are in imperial and metric, and measured from finish to finish excluding construction tolerances. 2. All materials, dimensions, and drawings are approximate only. 3. Information is subject to change without notice, at developer's absolute discretion. 4. Actual area may vary from the stated area. 5. Drawings not to scale. 6. All images used are for illustrative purposes only and do not represent the actual size, features, specifications, fittings, and furnishings. 7. The developer reserves the right to make revisions / alterations, at it's absolute discretion, without any liability whatsoever.

# ANYA 2

ARABIAN RANCHES III

ARIA

TOWNHOUSE

## 4 BEDROOM IM

MIRRORED

UNIT	TOTAL AREA	
4PLEX - TH04		
6PLEX - TH06	2462.67 SQFT	228.79 SQM
8PLEX - TH08		

### KEY PLAN

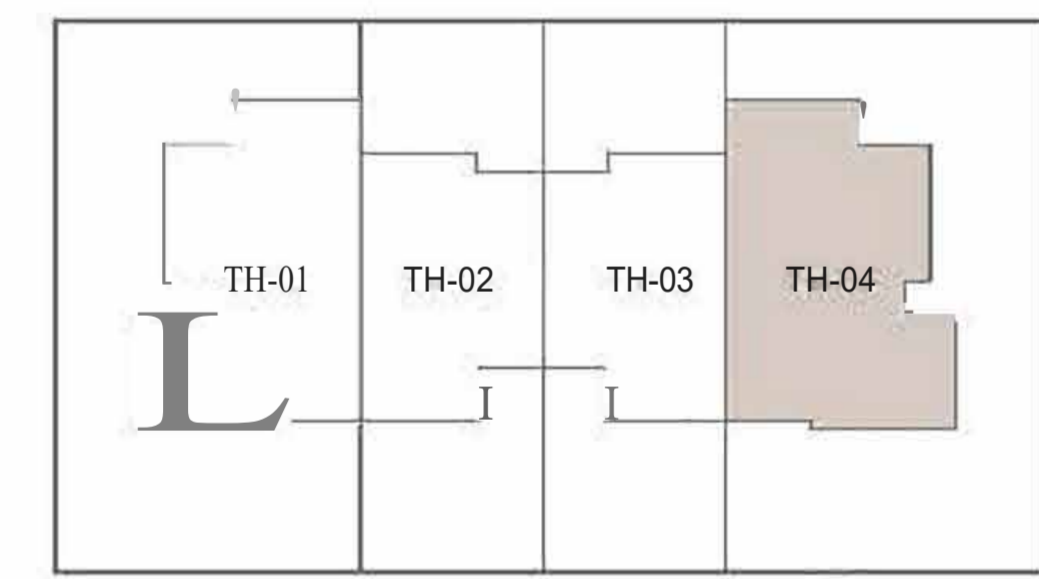

4PLEX - TH04

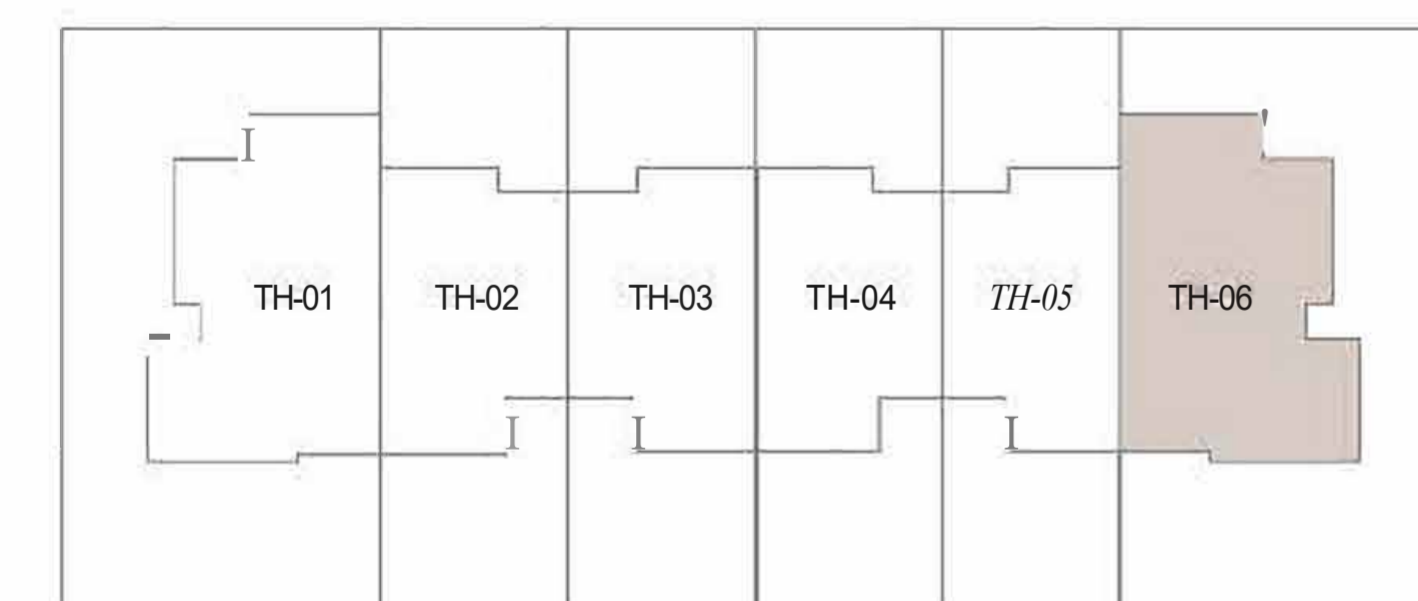

6PLEX - TH06

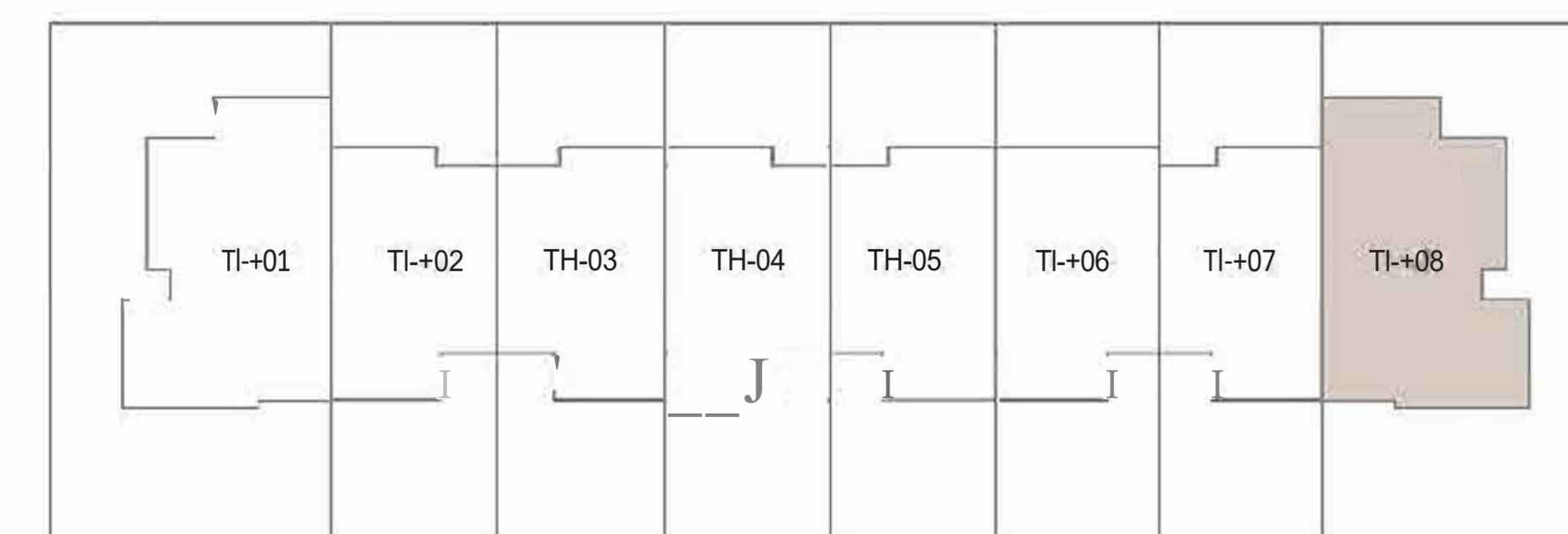

8PLEX - TH08

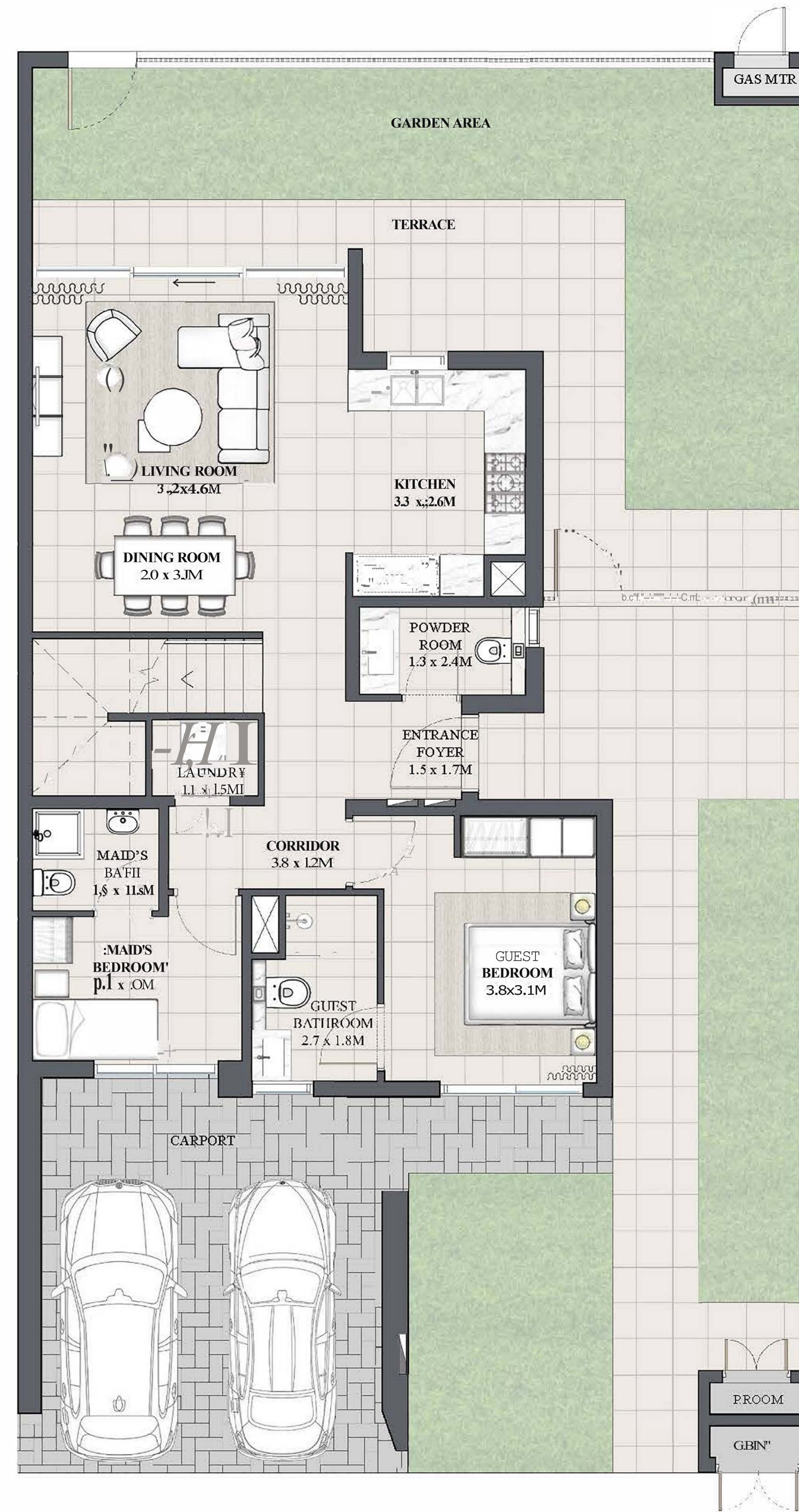

GROUND FLOOR

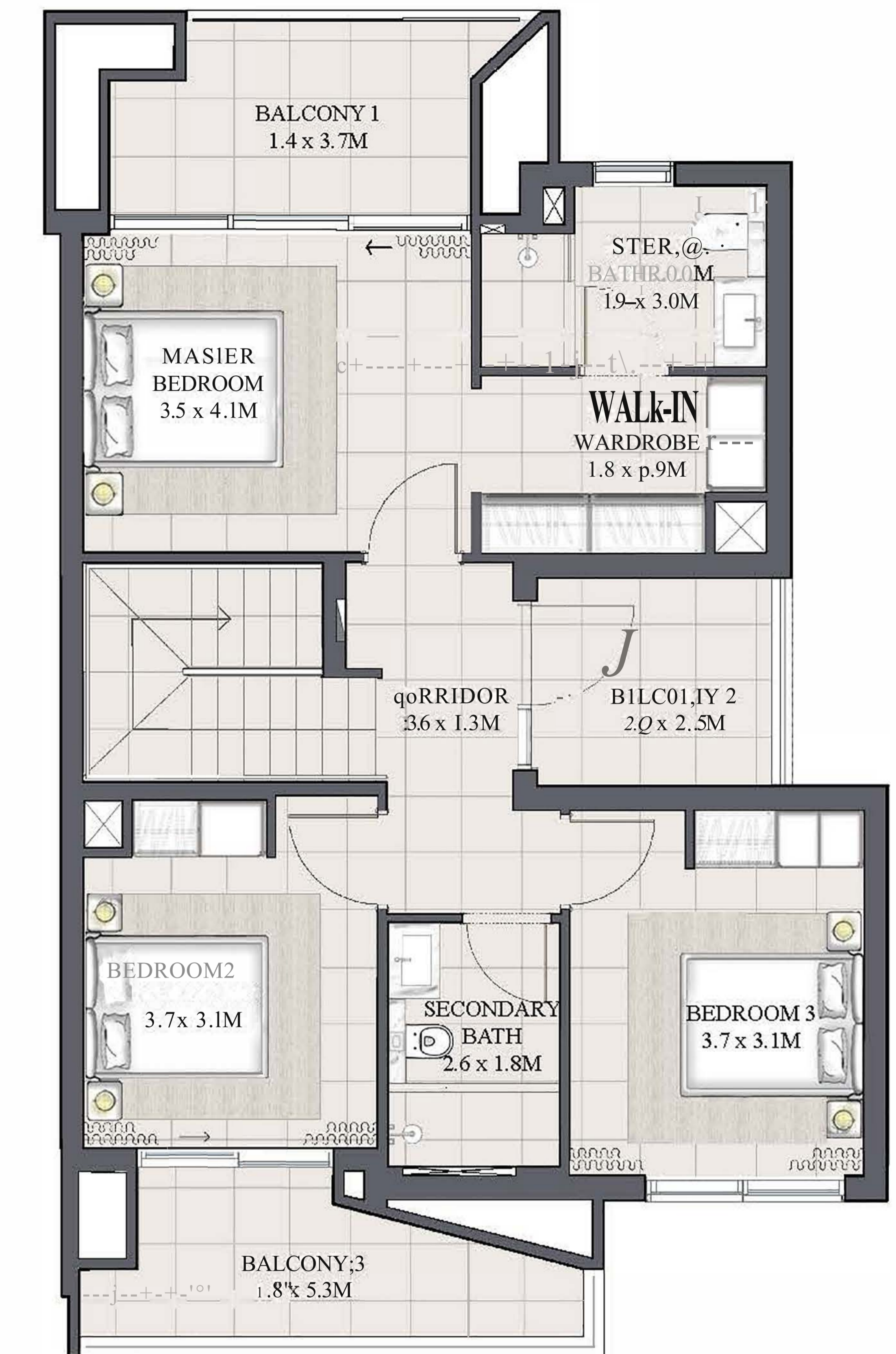

FIRST FLOOR

FLOOR PLAN 1. All dimensions are in imperial and metric, and measured from finish to finish excluding construction tolerances. 2. All materials, dimensions, and drawings are approximate only. 3. Information is subject to change without notice, at developer's absolute discretion. 4. Actual area may vary from the stated area. 5. Drawings not to scale. 6. All images used are for illustrative purposes only and do not represent the actual size, features, specifications, fittings, and furnishings. 7. The developer reserves the right to make revisions / alterations, at it's absolute discretion, without any liability whatsoever.

# ANYA 2

ARABIAN RANCHES III

ARIA

TOWNHOUSE

## 3 BEDROOM 1

UNIT	TOTAL AREA	
4PLEX - TH02		
6PLEX - TH02	1991.11 SQFT	184.98 SQM
8PLEX - TH02		

### KEY PLAN

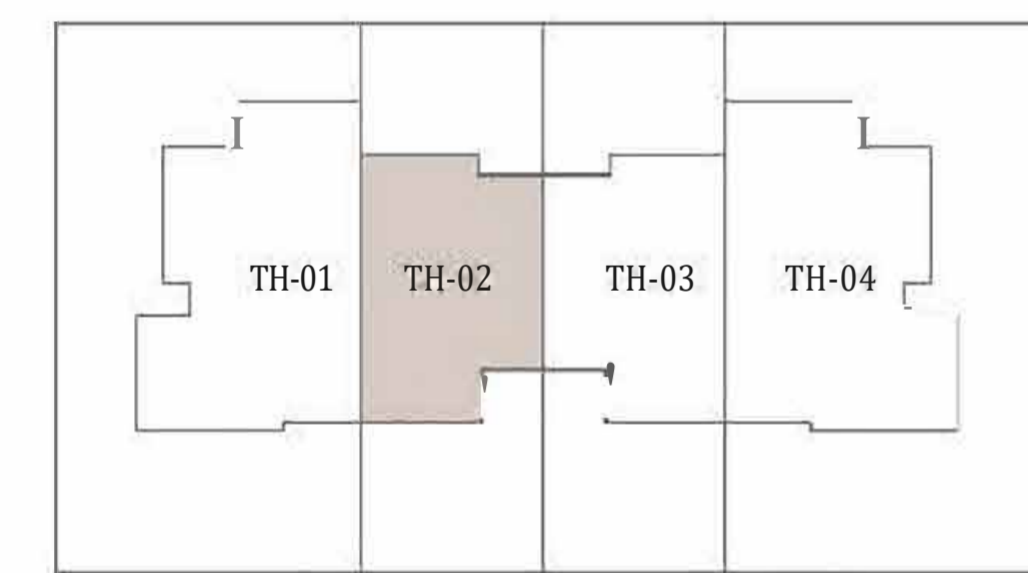

4PLEX - TH02

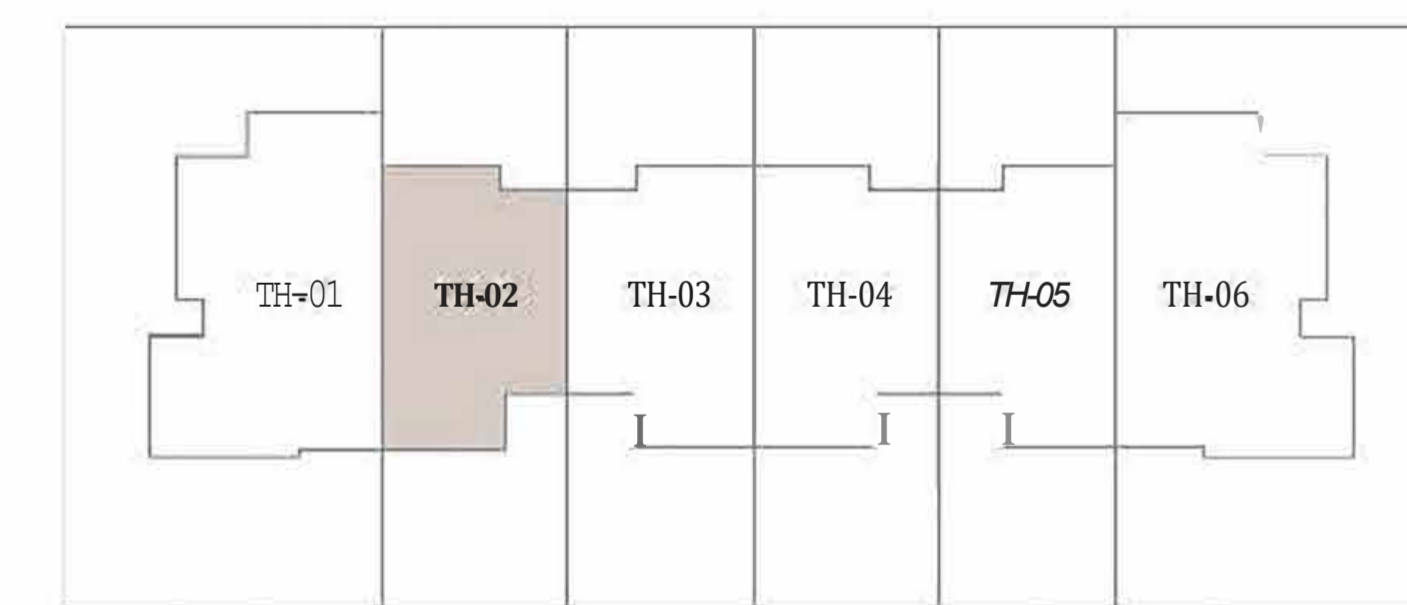

6PLEX - TH02

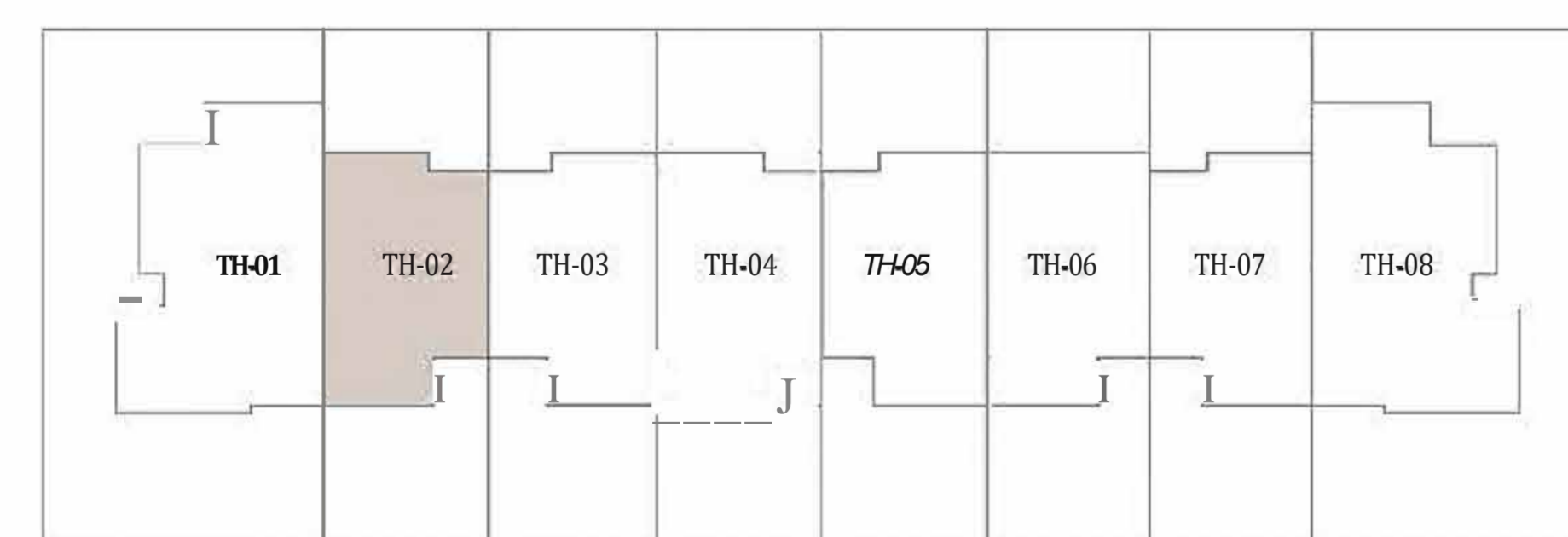

8PLEX - TH02

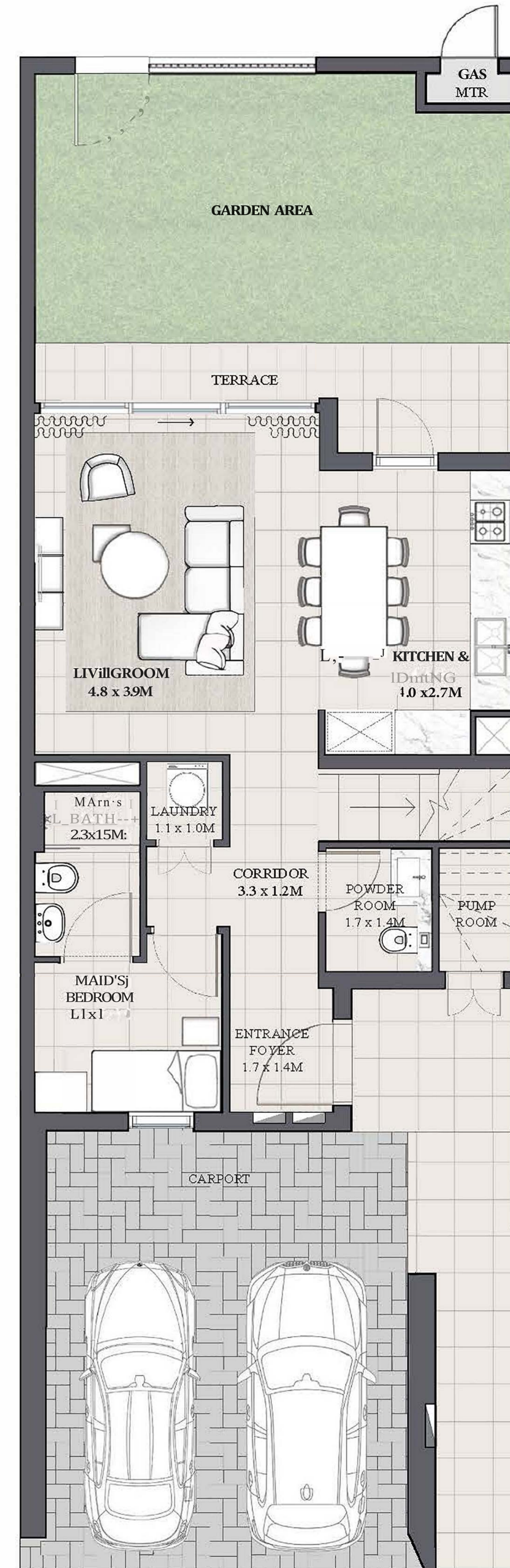

GROUND FLOOR

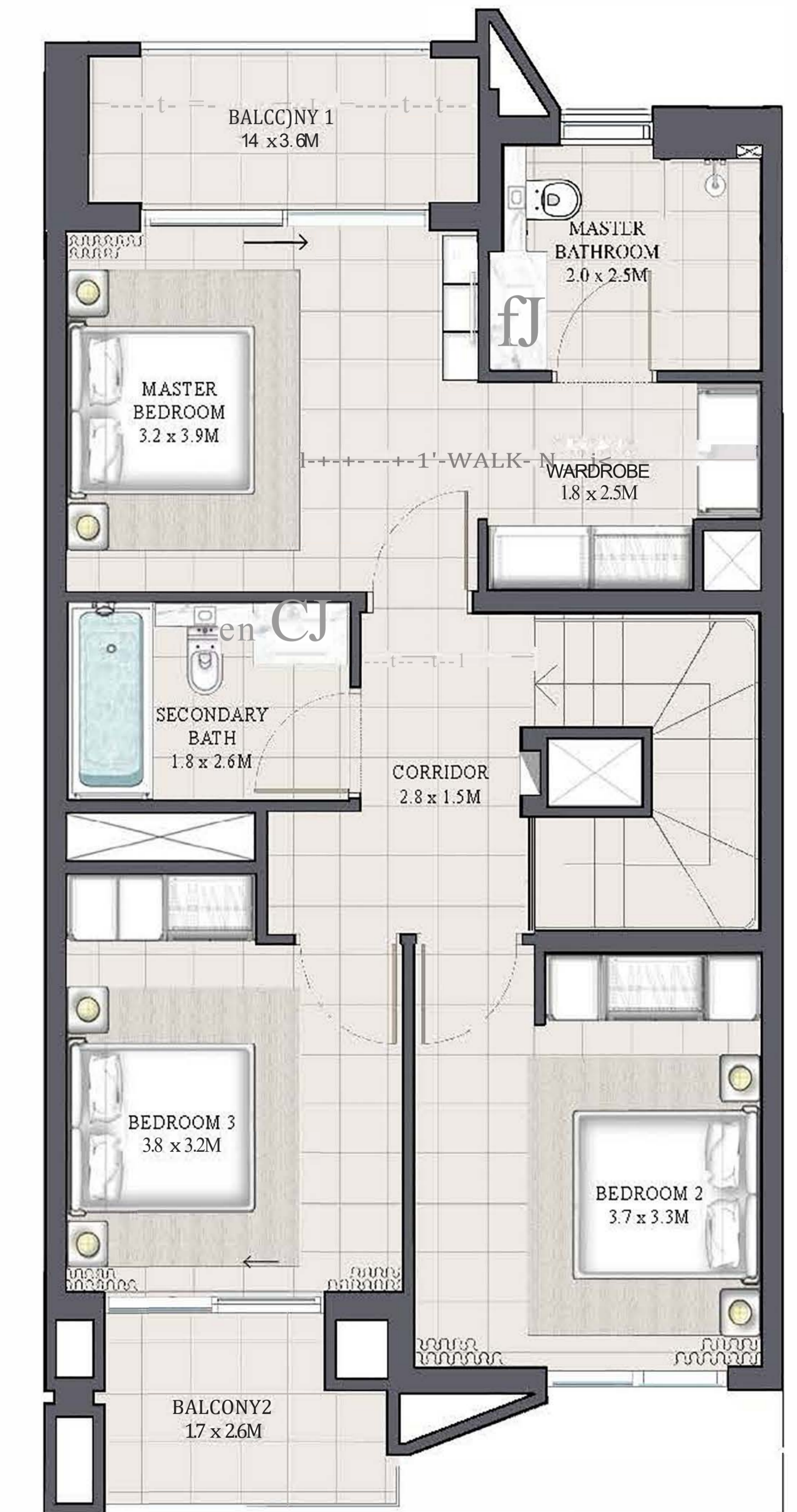

FIRST FLOOR

FLOOR PLAN 1. All dimensions are in imperial and metric, and measured from finish to finish excluding construction tolerances. 2. All materials, dimensions, and drawings are approximate only. 3. Information is subject to change without notice, at developer's absolute discretion. 4. Actual area may vary from the stated area. 5. Drawings not to scale. 6. All images used are for illustrative purposes only and do not represent the actual size, features, specifications, fittings, and furnishings. 7. The developer reserves the right to make revisions / alterations, at it's absolute discretion, without any liability whatsoever.

# ANYA 2

ARABIAN RANCHES III

ARIA

TOWNHOUSE

## 3 BEDROOM IM

MIRRORED

UNIT	TOTAL AREA	
4PLEX - TH03		
6PLEX - TH05	1991.11 SQFT	184.98 SQM
8PLEX - TH07		

### KEY PLAN

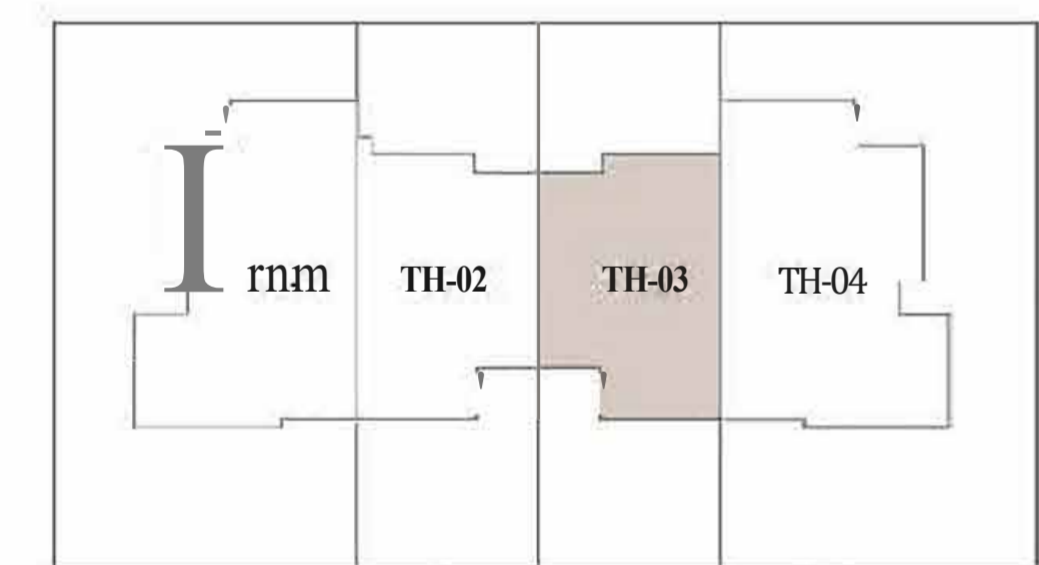

4PLEX - TH03

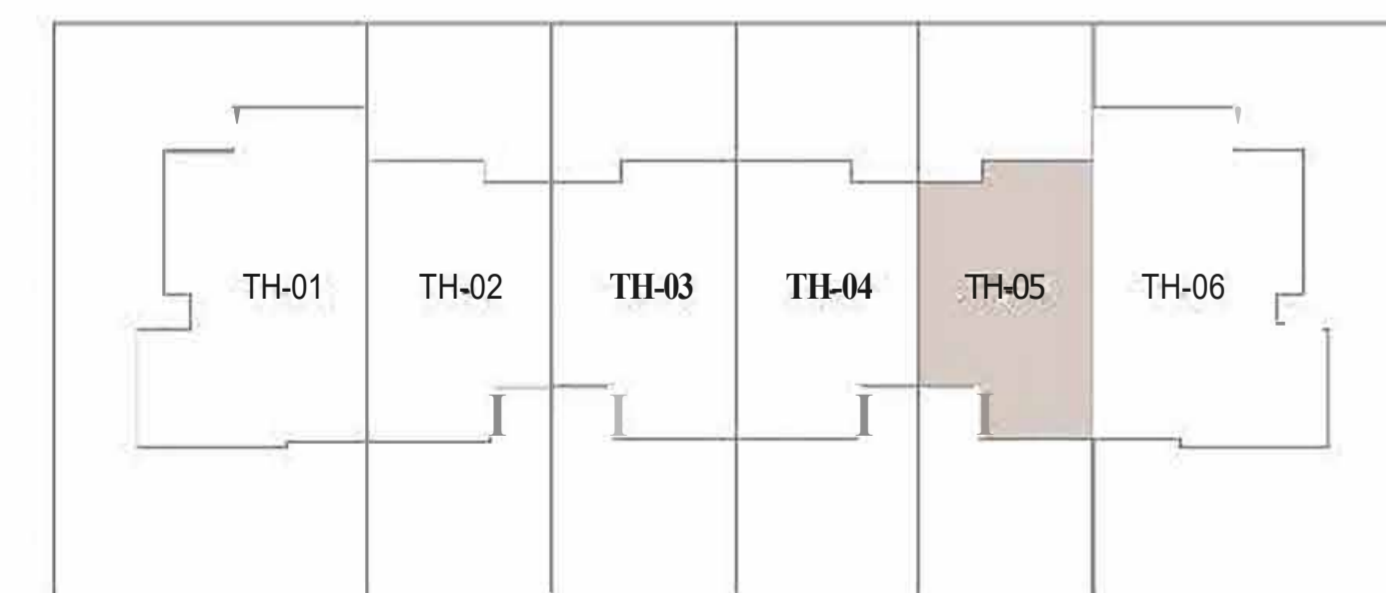

6PLEX - TH05

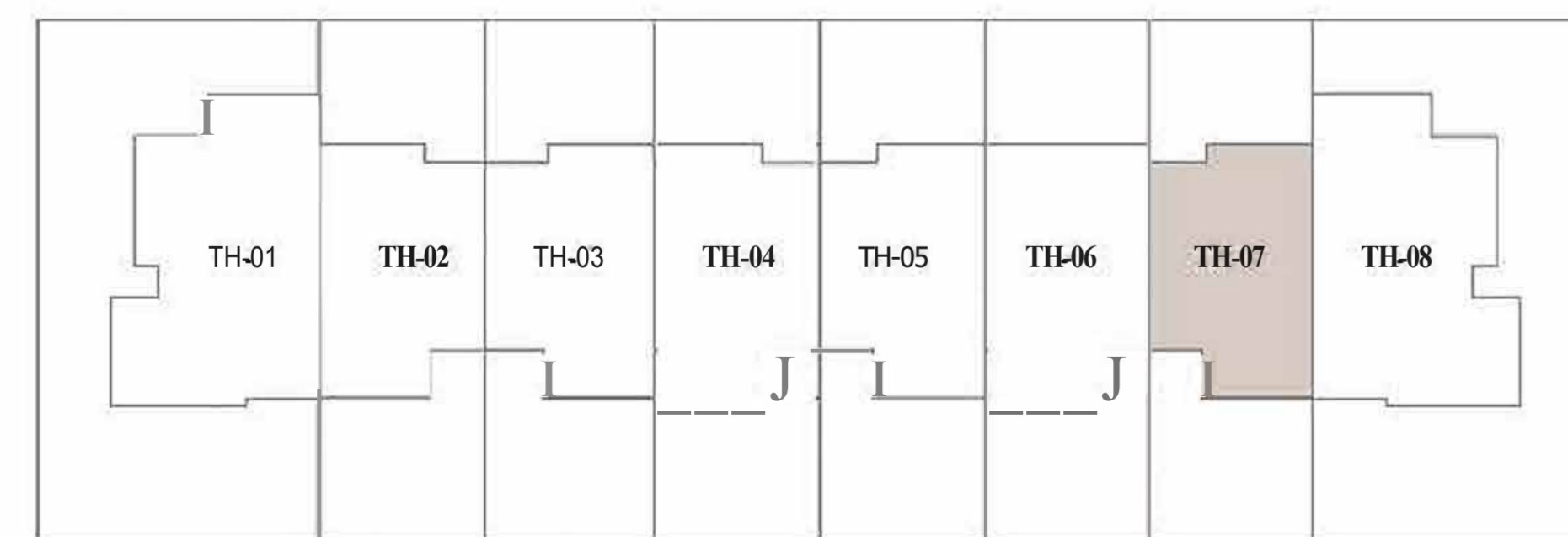

8PLEX - TH07

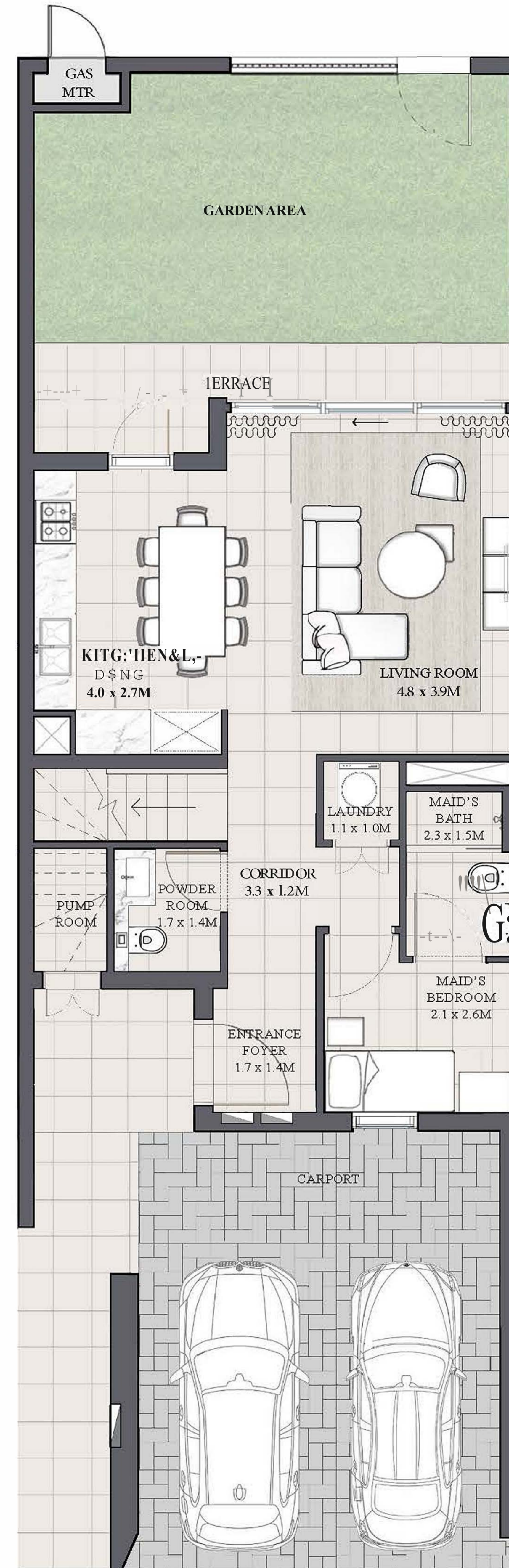

GROUND FLOOR

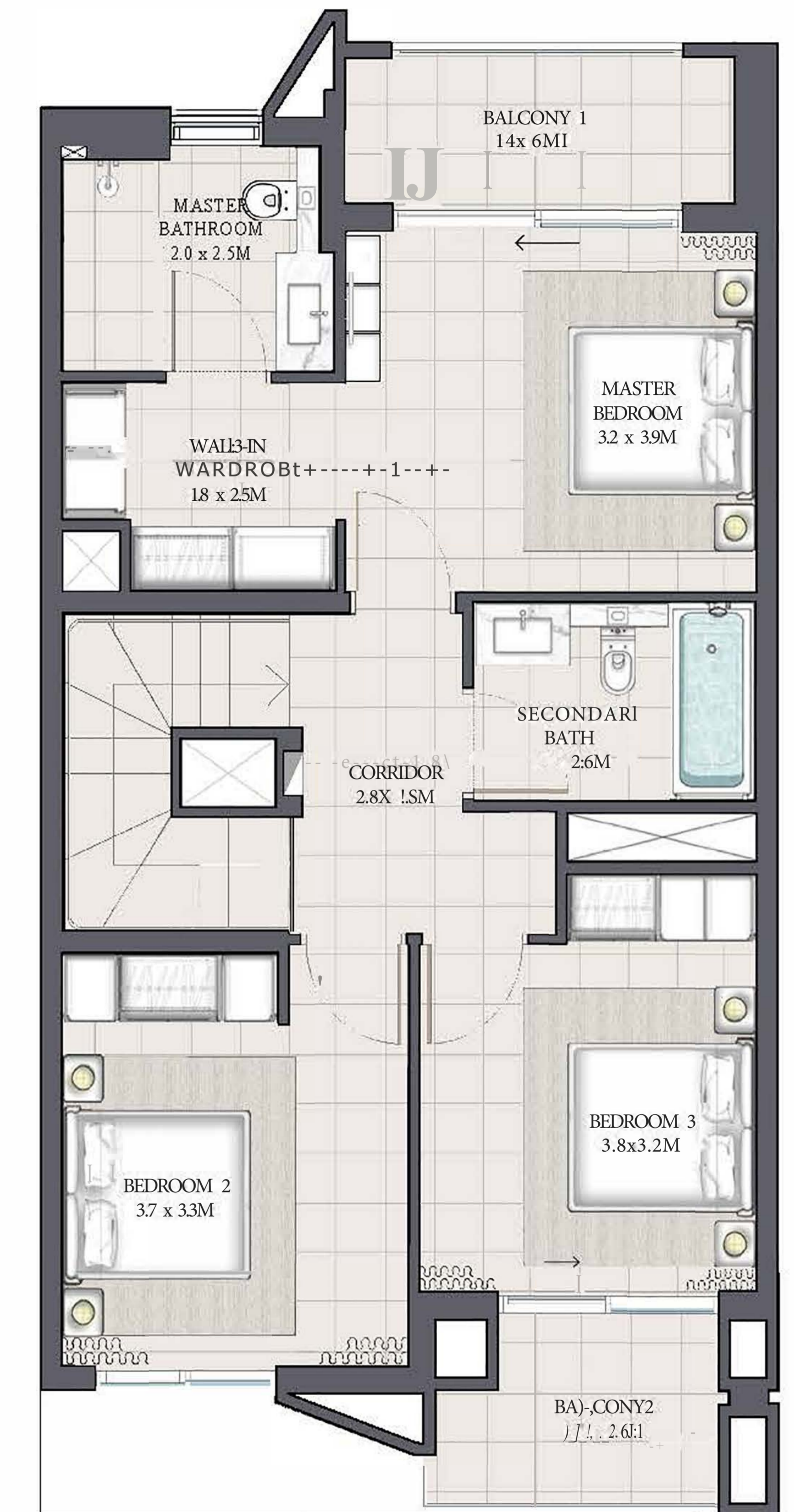

FIRST FLOOR

FLOOR PLAN 1. All dimensions are in imperial and metric, and measured from finish to finish excluding construction tolerances. 2. All materials, dimensions, and drawings are approximate only. 3. Information is subject to change without notice, at developer's absolute discretion. 4. Actual area may vary from the stated area. 5. Drawings not to scale. 6. All images used are for illustrative purposes only and do not represent the actual size, features, specifications, fittings, and furnishings. 7. The developer reserves the right to make revisions / alterations, at it's absolute discretion, without any liability whatsoever.



# ANYA 2

ARABIAN RANCHES III

ARIA

TOWNHOUSE

## 3 BEDROOM 2

UNIT	TOTAL AREA	
6PLEX - TH03	1985.29 SQFT	184.44 SQM
8PLEX - TH03	1985.19 SQFT	184.43 SQM
8PLEX - TH05	1988.74 SQFT	184.76 SQM

### KEY PLAN

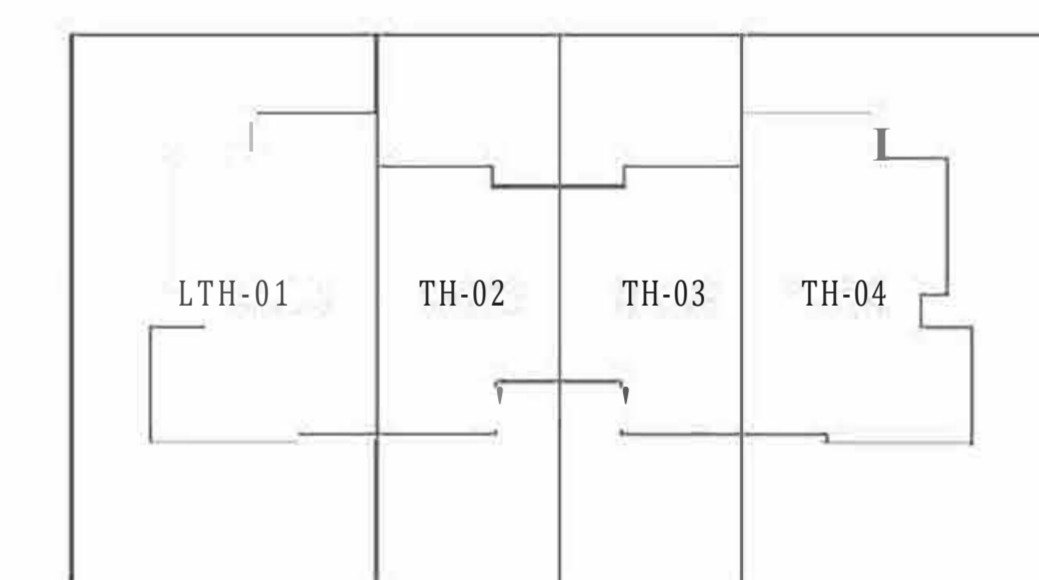

4PLEX

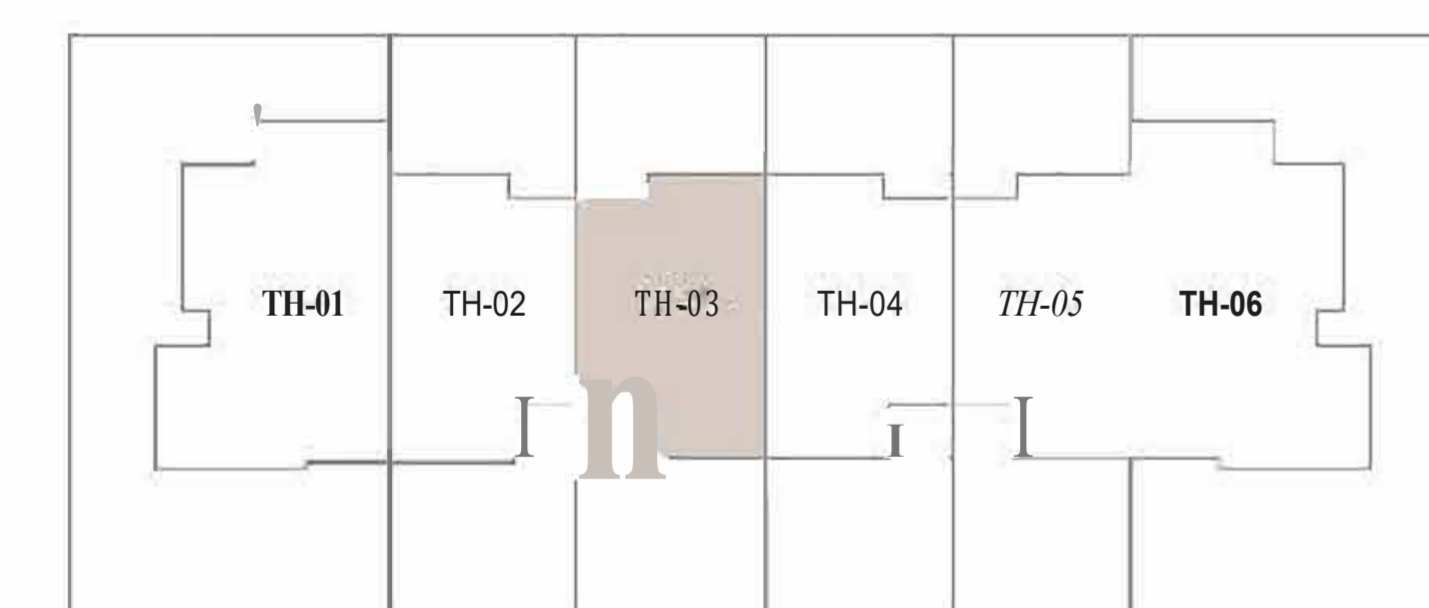

6PLEX - TH03

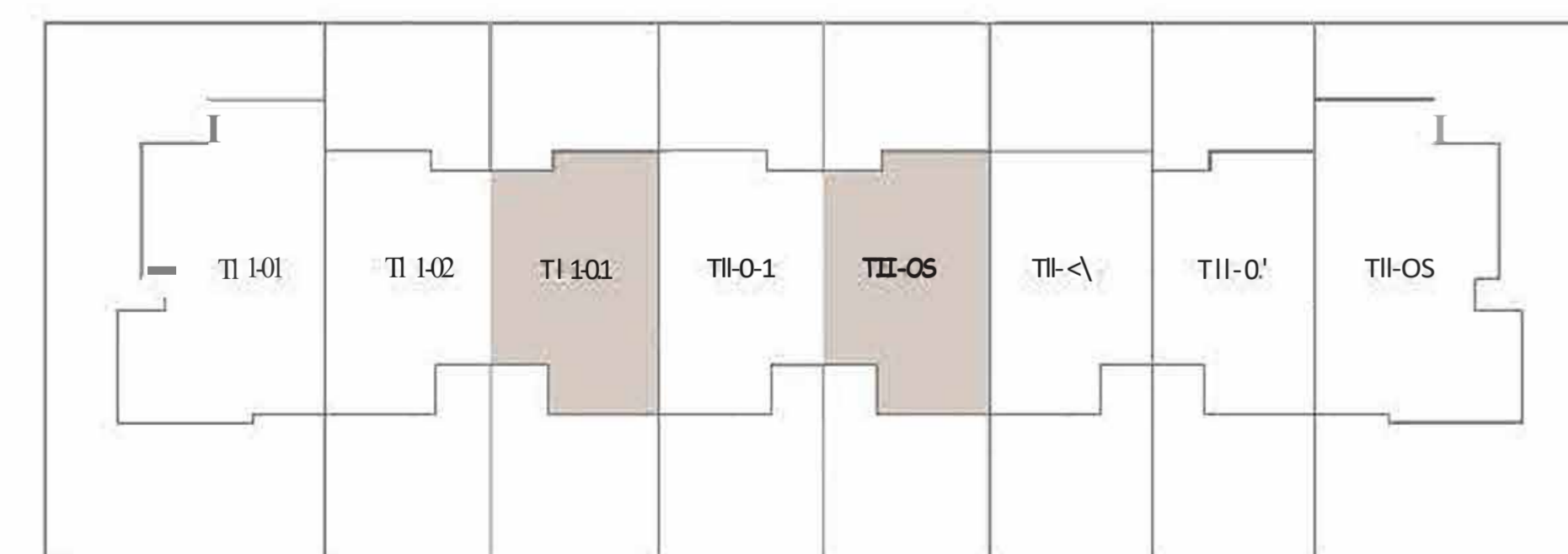

8PLEX - TH03, TH05

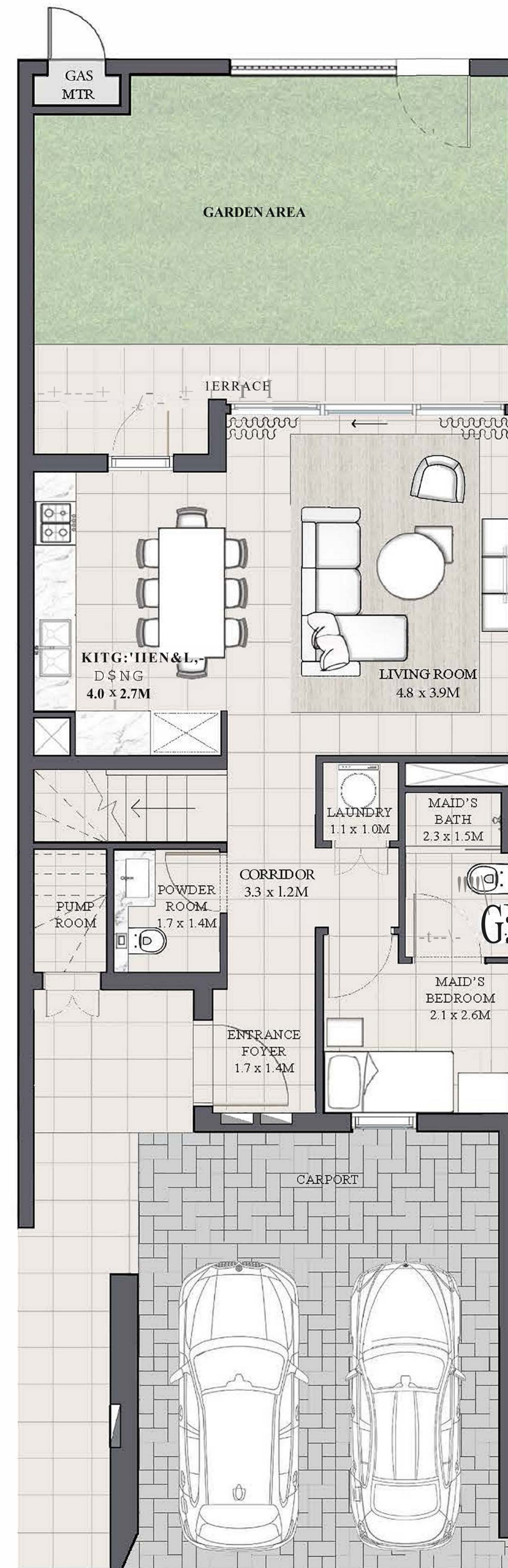

GROUND FLOOR

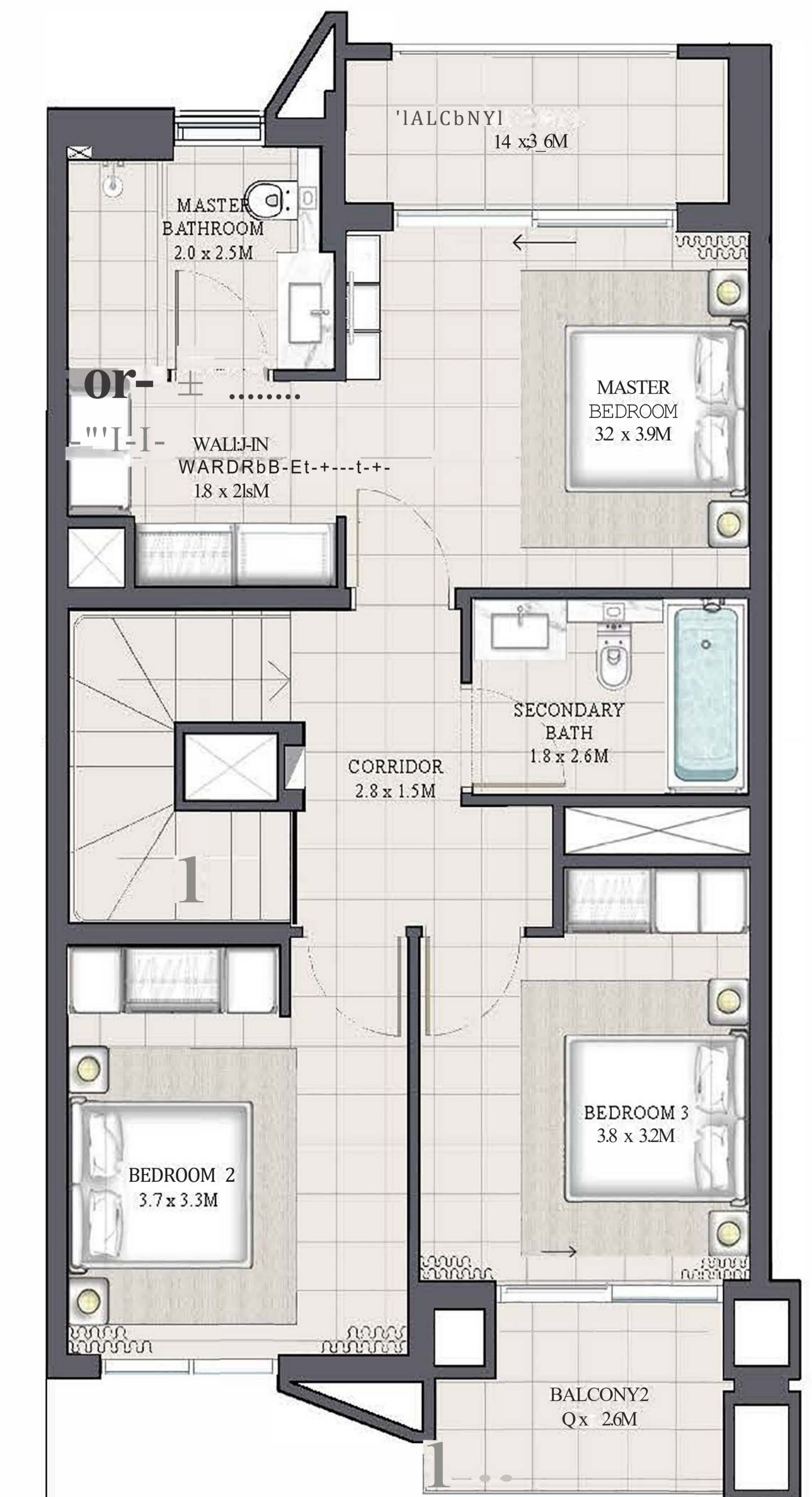

FIRST FLOOR

FLOOR PLAN 1. All dimensions are in imperial and metric, and measured from finish to finish excluding construction tolerances. 2. All materials, dimensions, and drawings are approximate only. 3. Information is subject to change without notice, at developer's absolute discretion. 4. Actual area may vary from the stated area. 5. Drawings not to scale. 6. All images used are for illustrative purposes only and do not represent the actual size, features, specifications, fittings, and furnishings. 7. The developer reserves the right to make revisions / alterations, at it's absolute discretion, without any liability whatsoever.

# ANYA 2

ARABIAN RANCHES III

## ARIA TOWNHOUSE 3 BEDROOM 2M MIRRORED

UNIT	TOTAL AREA	
6PLEX - TH04	1988.74 SQFT	184.76 SQM
8PLEX - TH04	1985.19SQFT	184.43 SQM

### KEY PLAN

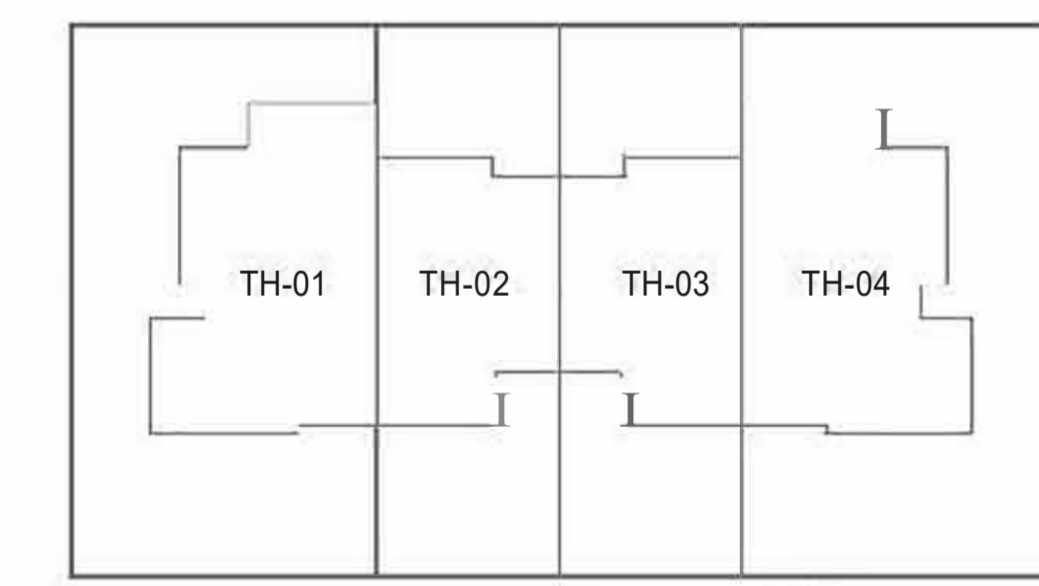

4PLEX

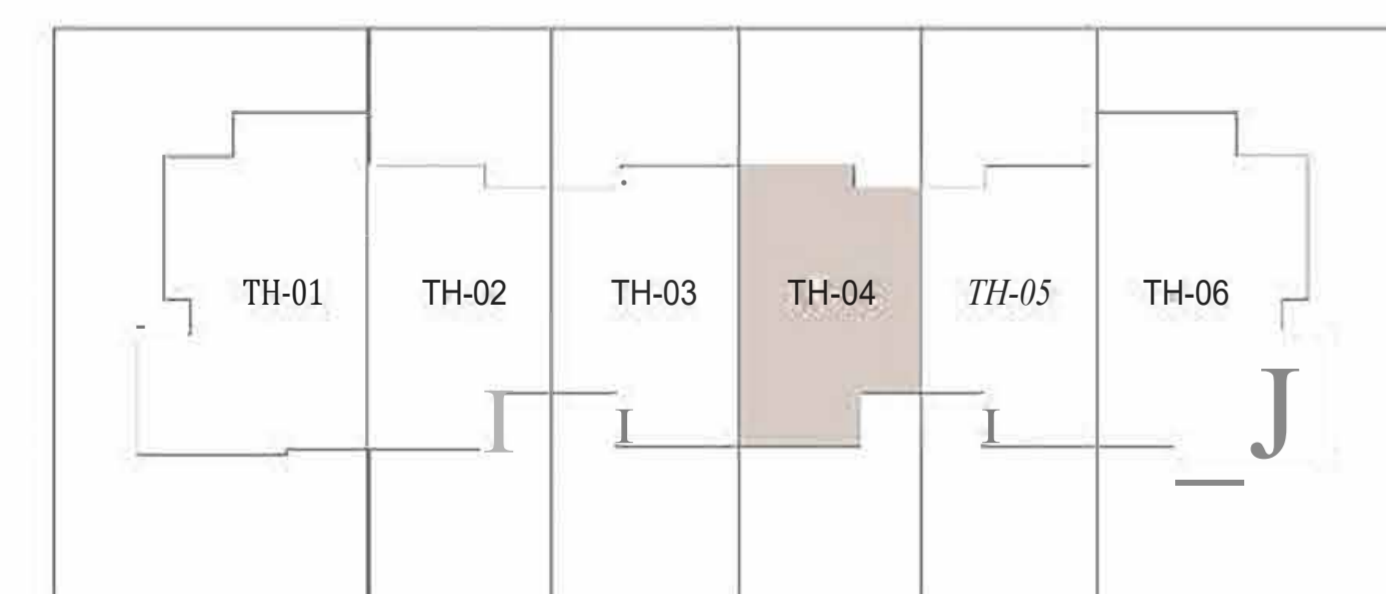

6PLEX - TH04

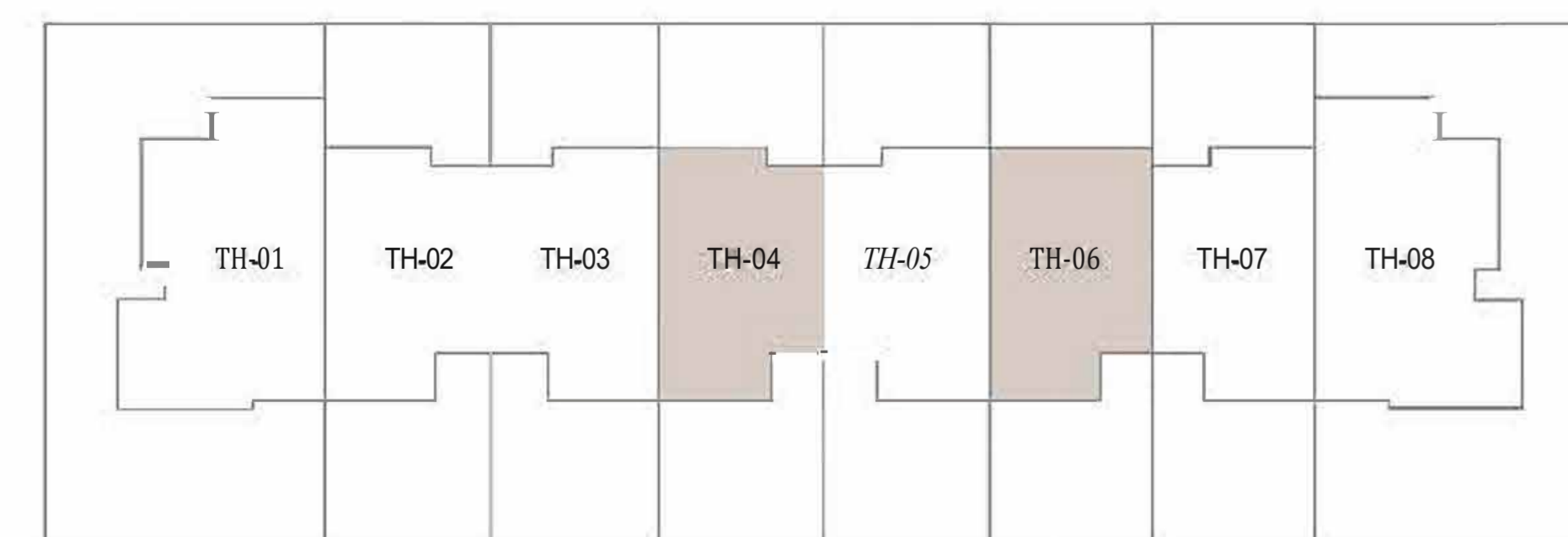

8PLEX - TH04, TH06

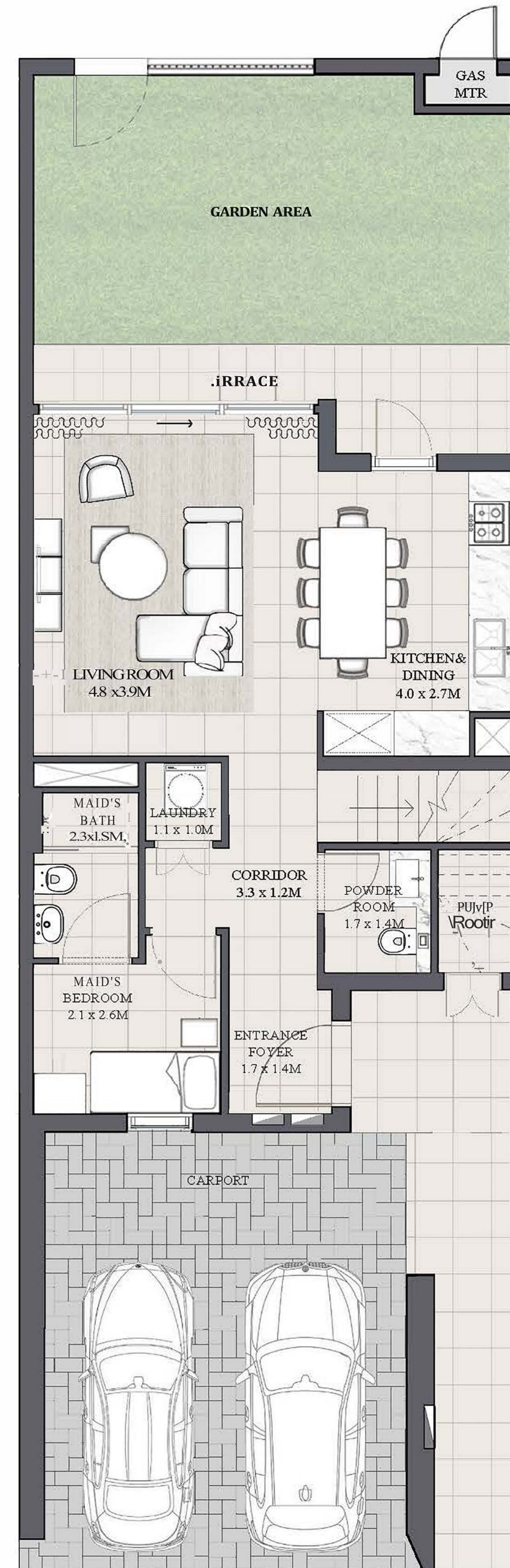

GROUND FLOOR



FIRST FLOOR

FLOOR PLAN 1. All dimensions are in imperial and metric, and measured from finish to finish excluding construction tolerances. 2. All materials, dimensions, and drawings are approximate only. 3. Information is subject to change without notice, at developer's absolute discretion. 4. Actual area may vary from the stated area. 5. Drawings not to scale. 6. All images used are for illustrative purposes only and do not represent the actual size, features, specifications, fittings, and furnishings. 7. The developer reserves the right to make revisions / alterations, at it's absolute discretion, without any liability whatsoever.

# ANYA 2

ARABIAN RANCHES III

## IRIS TOWNHOUSE 4 BEDROOM 1

UNIT	TOTAL AREA	
4PLEX - TH01		
6PLEX - TH01	2457.29 SQFT	228.29 SQM
8PLEX - TH01		

### KEY PLAN

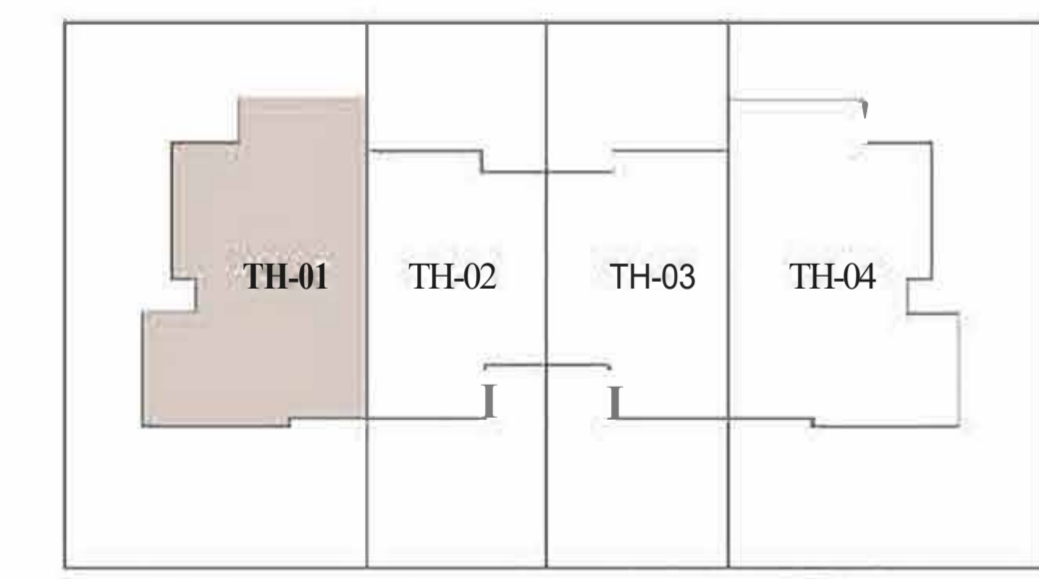

4PLEX - TH01

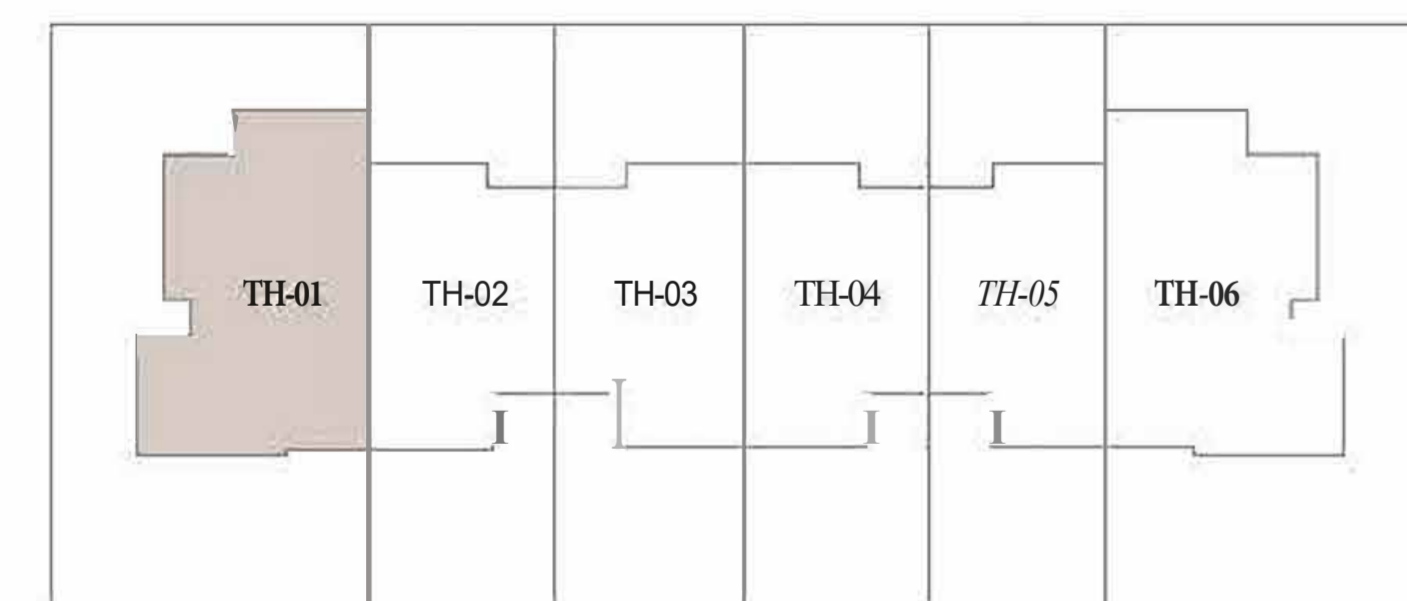

6PLEX - TH01

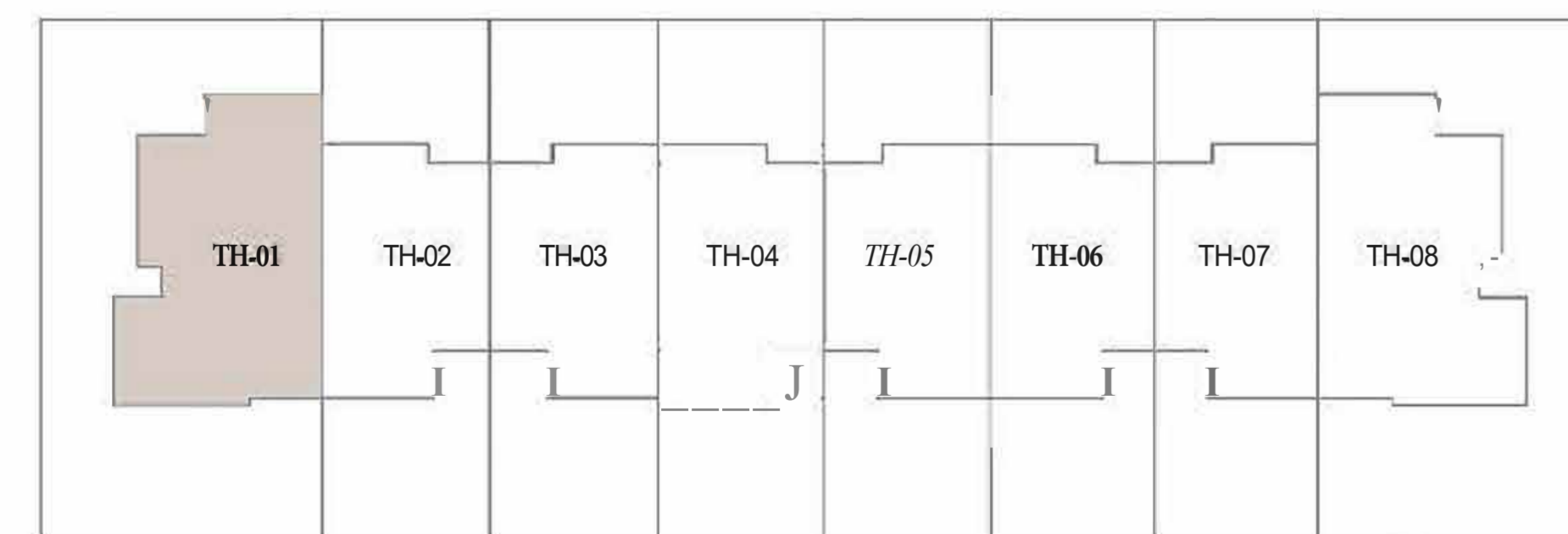

8PLEX - TH01

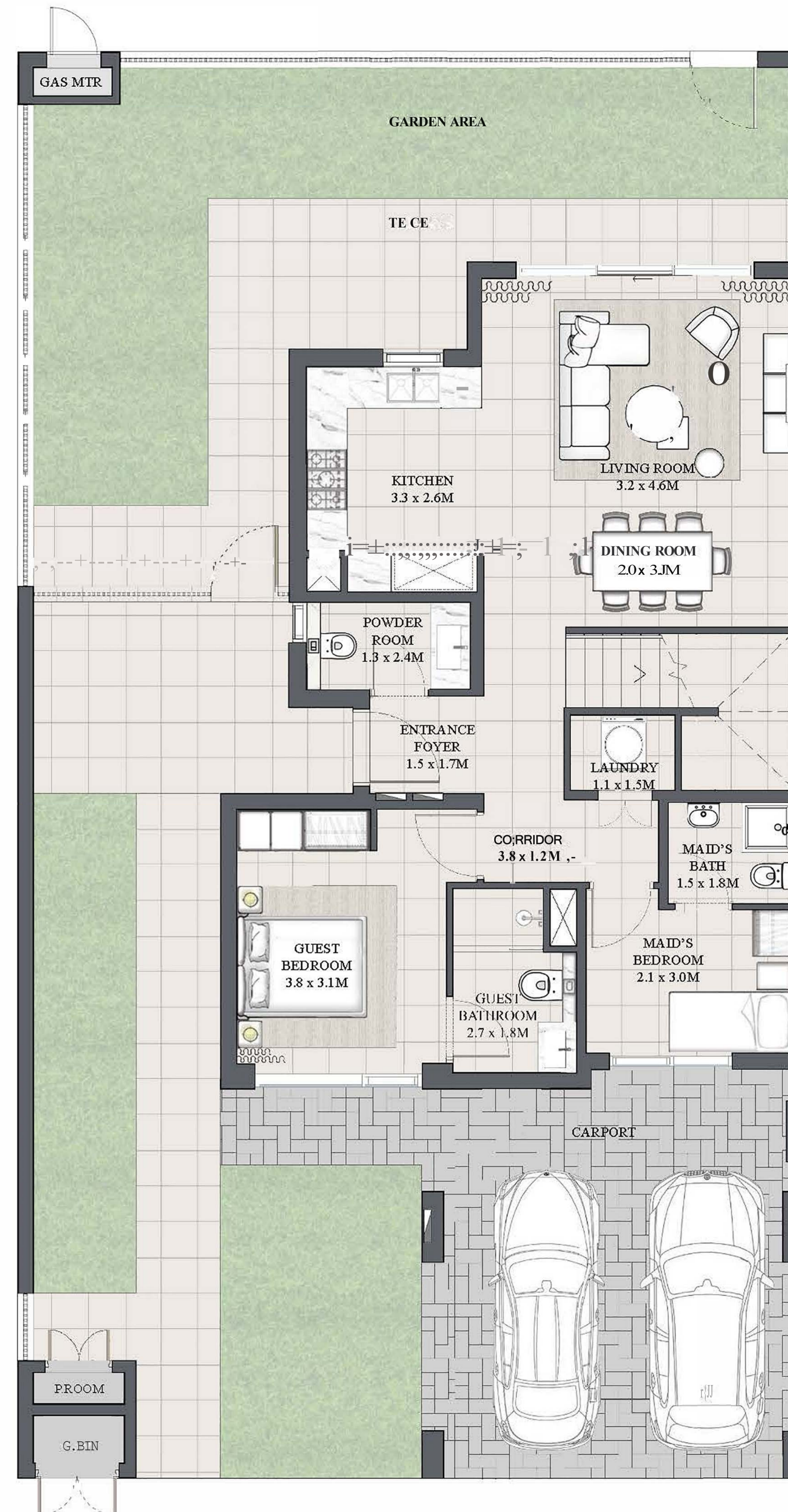

GROUND FLOOR

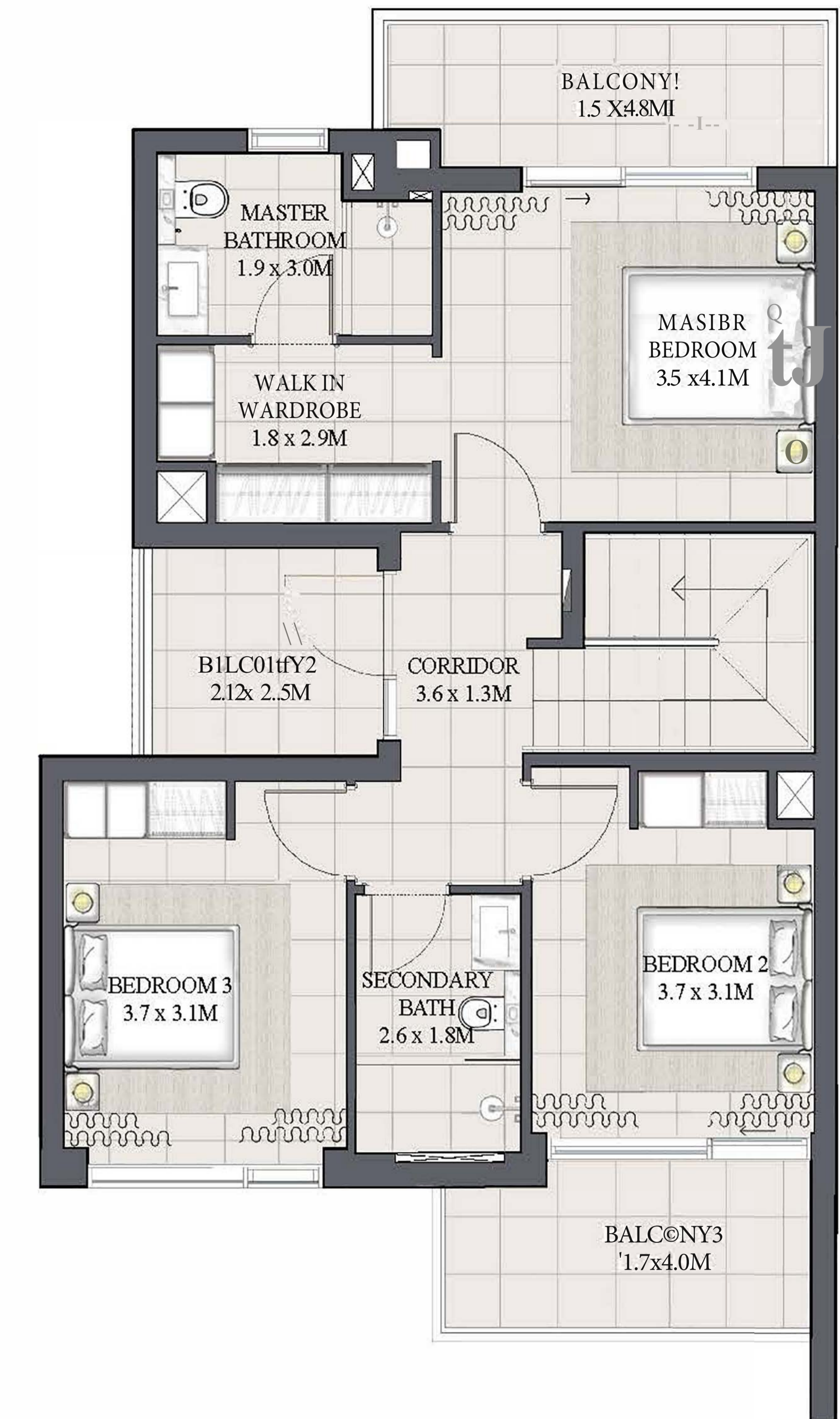

FIRST FLOOR

FLOOR PLAN 1, All dimensions are in imperial and metric, and measured from finish to finish excluding construction tolerances, 2, All materials, dimensions, and drawings are approximate only, 3, Information is subject to change without notice, at developer's absolute discretion, 4, Actual area may vary from the stated area, 5, Drawings not to scale, 6, All images used are for illustrative purposes only and do not represent the actual size, features, specifications, fittings, and furnishings, 7, The developer reserves the right to make revisions / alterations, at it's absolute discretion, without any liability whatsoever,

# ANYA 2

ARABIAN RANCHES III

IRIS

TOWNHOUSE

**4 BEDROOM IM**  
MIRRORED

UNIT	TOTAL AREA	
4PLEX - TH04		
6PLEX - TH06	2457.29 SQFT	228.29 SQM
8PLEX - TH08		

## KEY PLAN

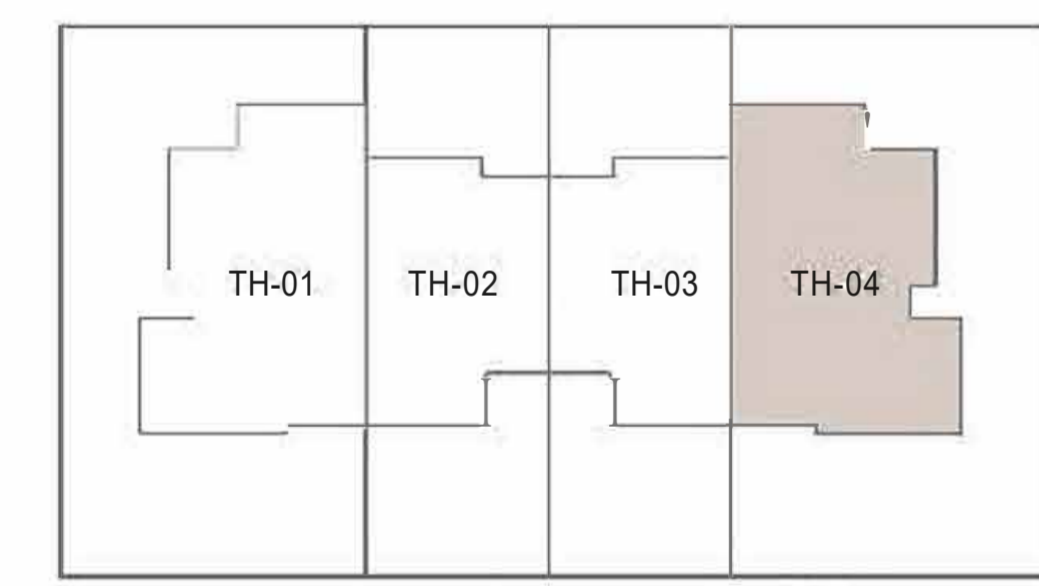

4PLEX - TH04

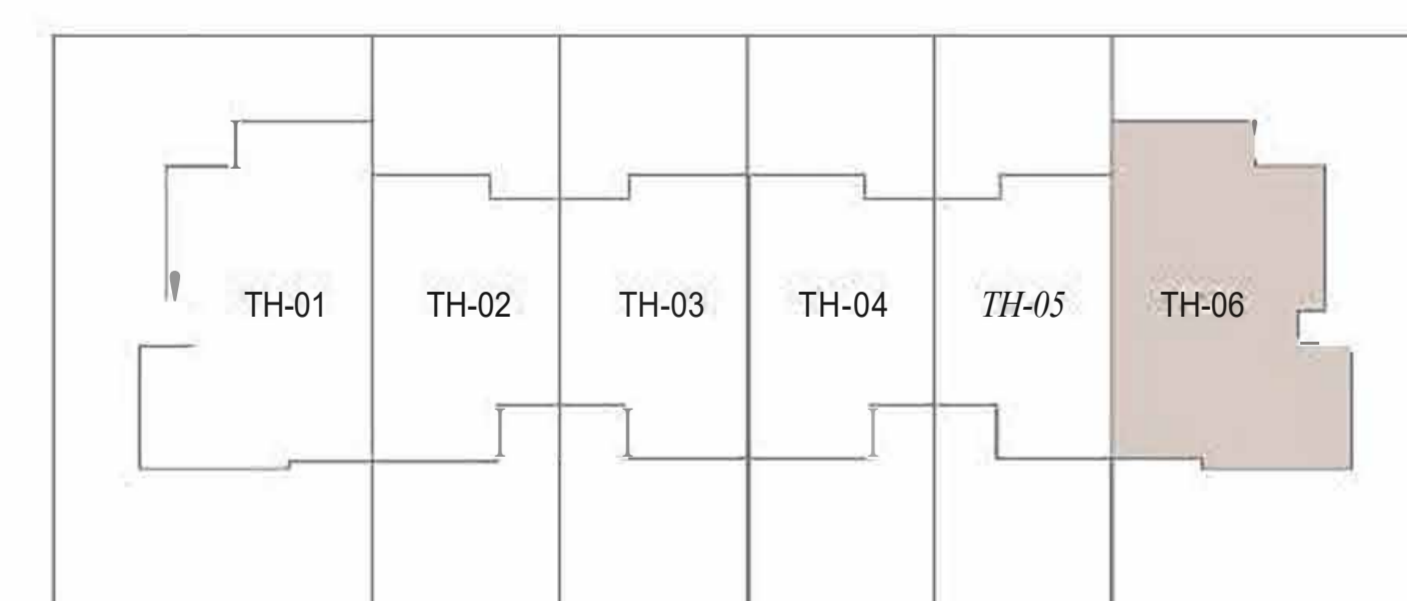

6PLEX - TH06

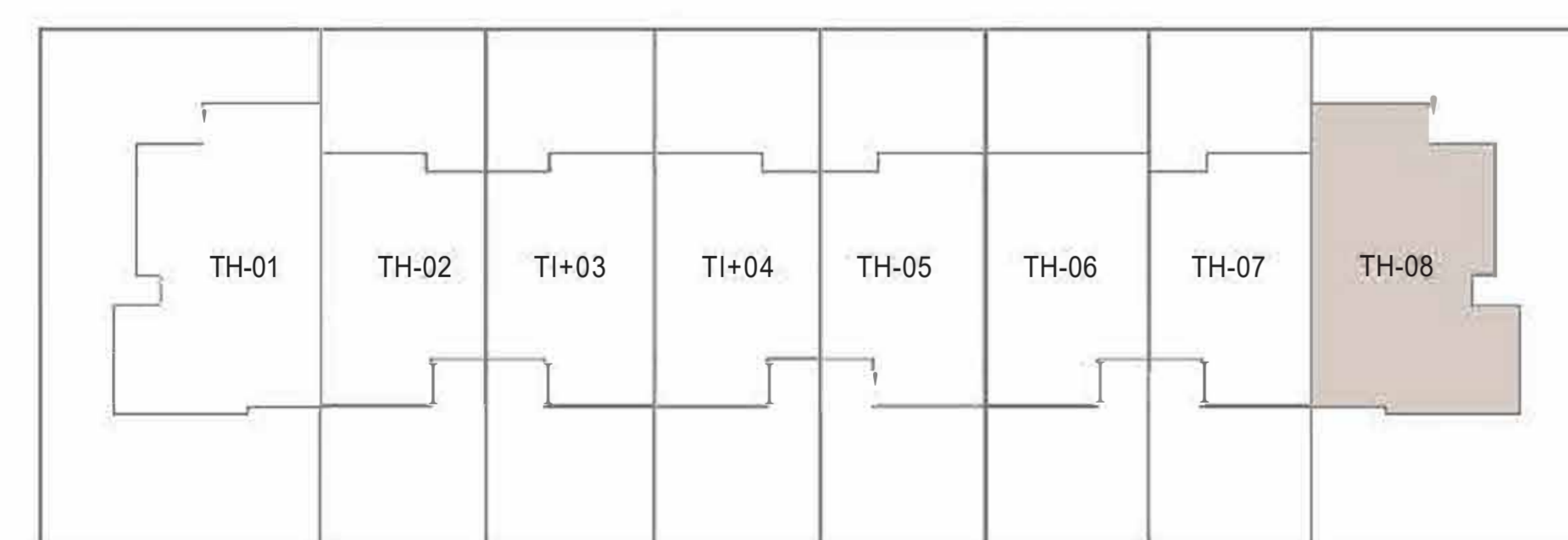

8PLEX - TH08

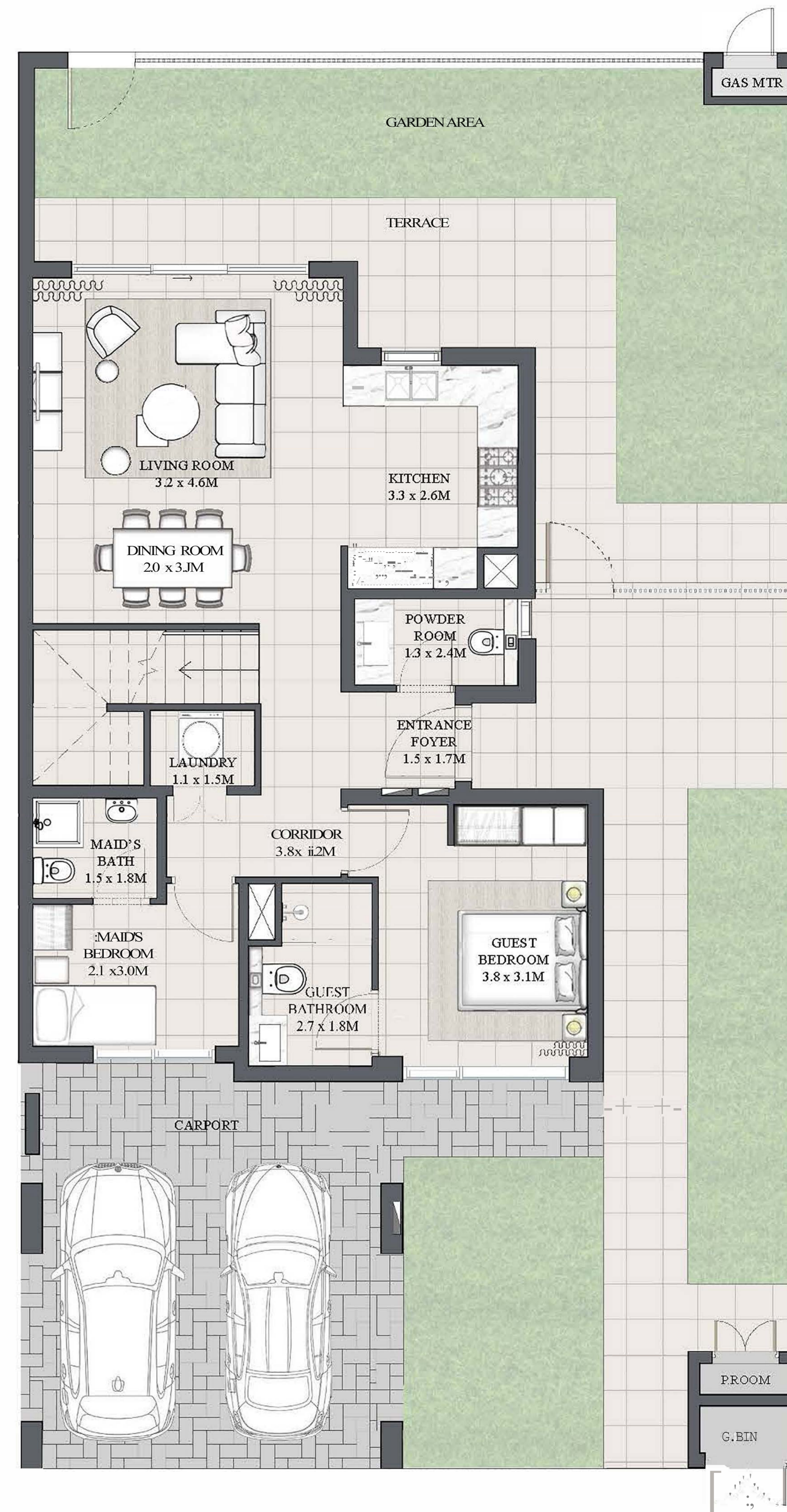

GROUND FLOOR

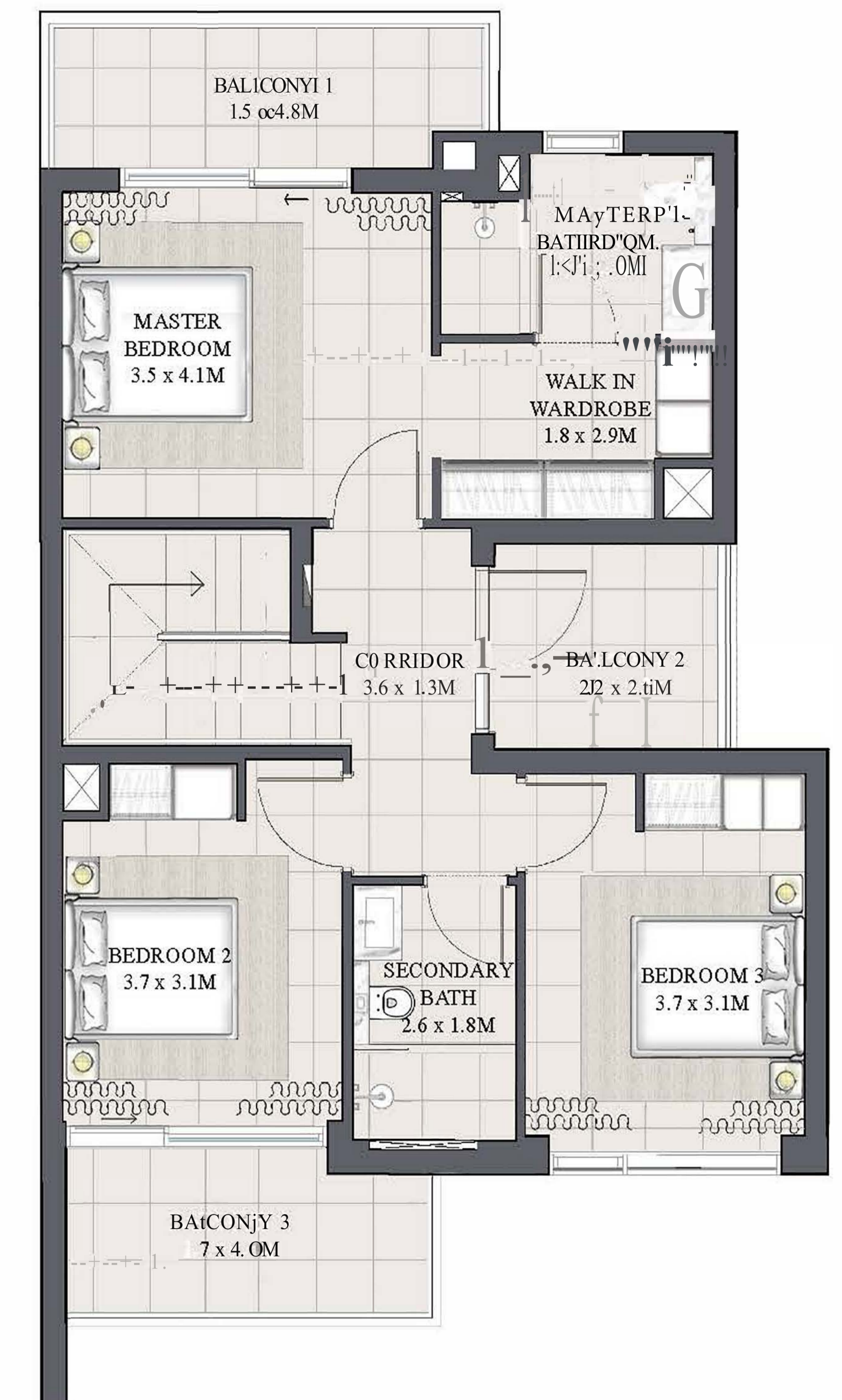

FIRST FLOOR

FLOOR PLAN 1. All dimensions are in imperial and metric, and measured from finish to finish excluding construction tolerances. 2. All materials, dimensions, and drawings are approximate only. 3. Information is subject to change without notice, at developer's absolute discretion. 4. Actual area may vary from the stated area. 5. Drawings not to scale. 6. All images used are for illustrative purposes only and do not represent the actual size, features, specifications, fittings, and furnishings. 7. The developer reserves the right to make revisions / alterations, at it's absolute discretion, without any liability whatsoever.

# ANYA 2

ARABIAN RANCHES III

## IRIS TOWNHOUSE 3 BEDROOM 1

UNIT	TOTAL AREA	
4PLEX - TH02		
6PLEX - TH02	2038.79 SQFT	189.41 SQM
8PLEX - TH02		

### KEY PLAN

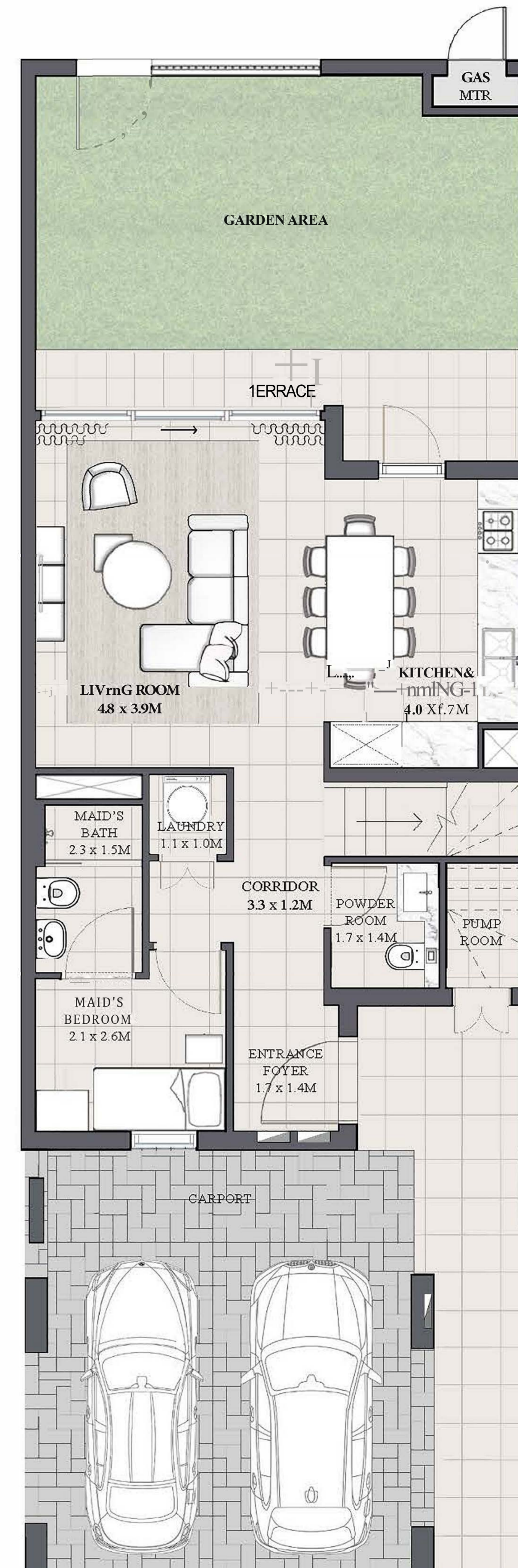
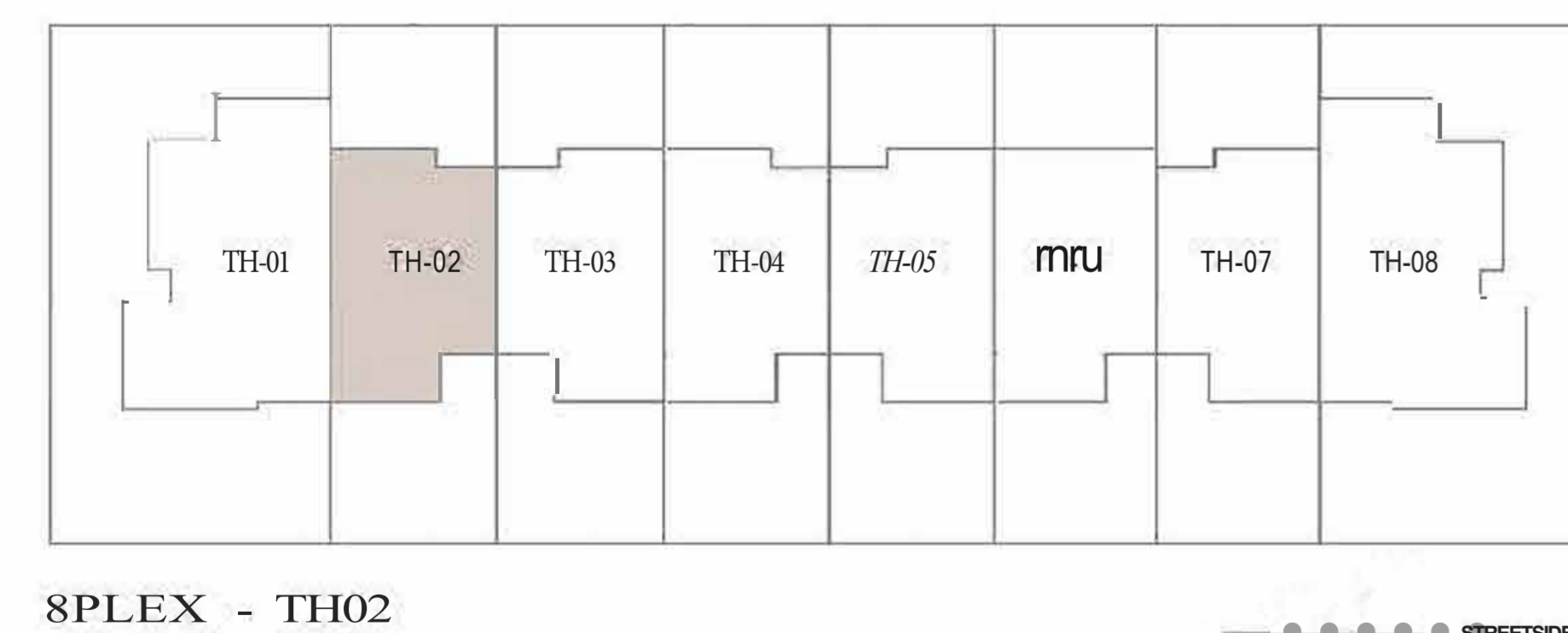
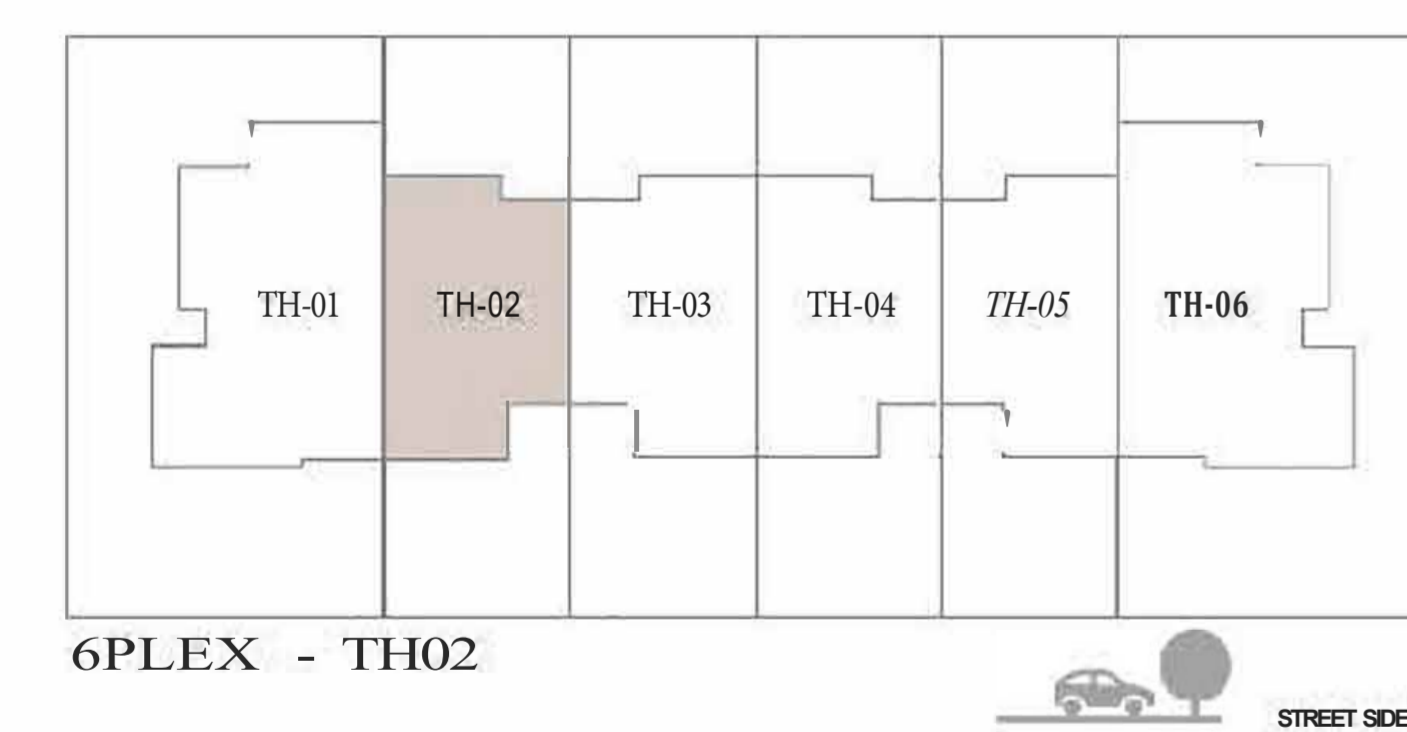
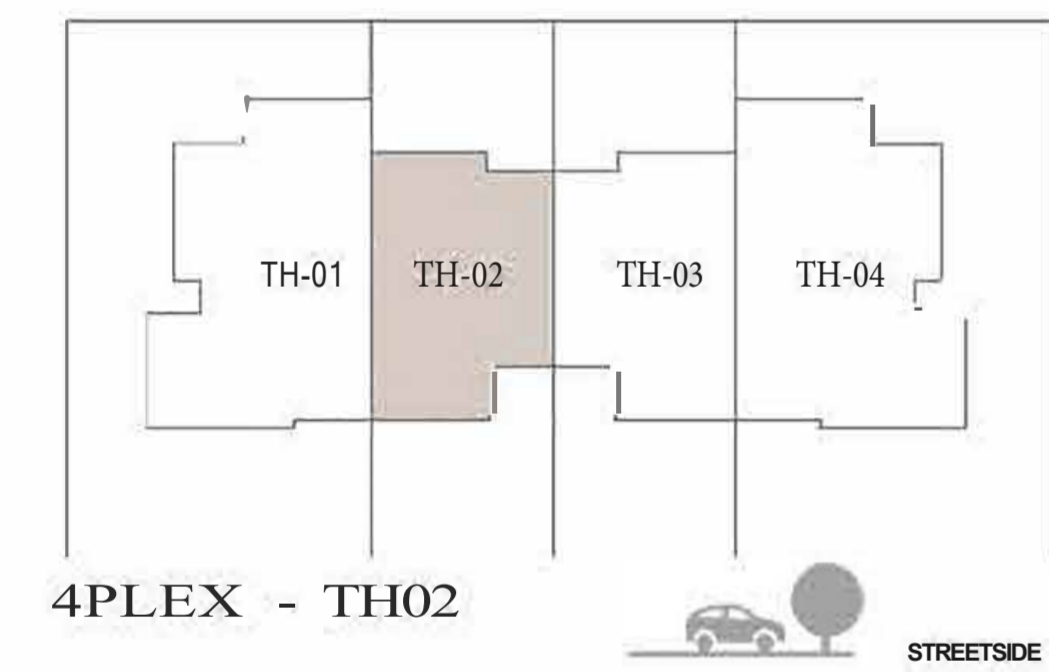

GROUND FLOOR

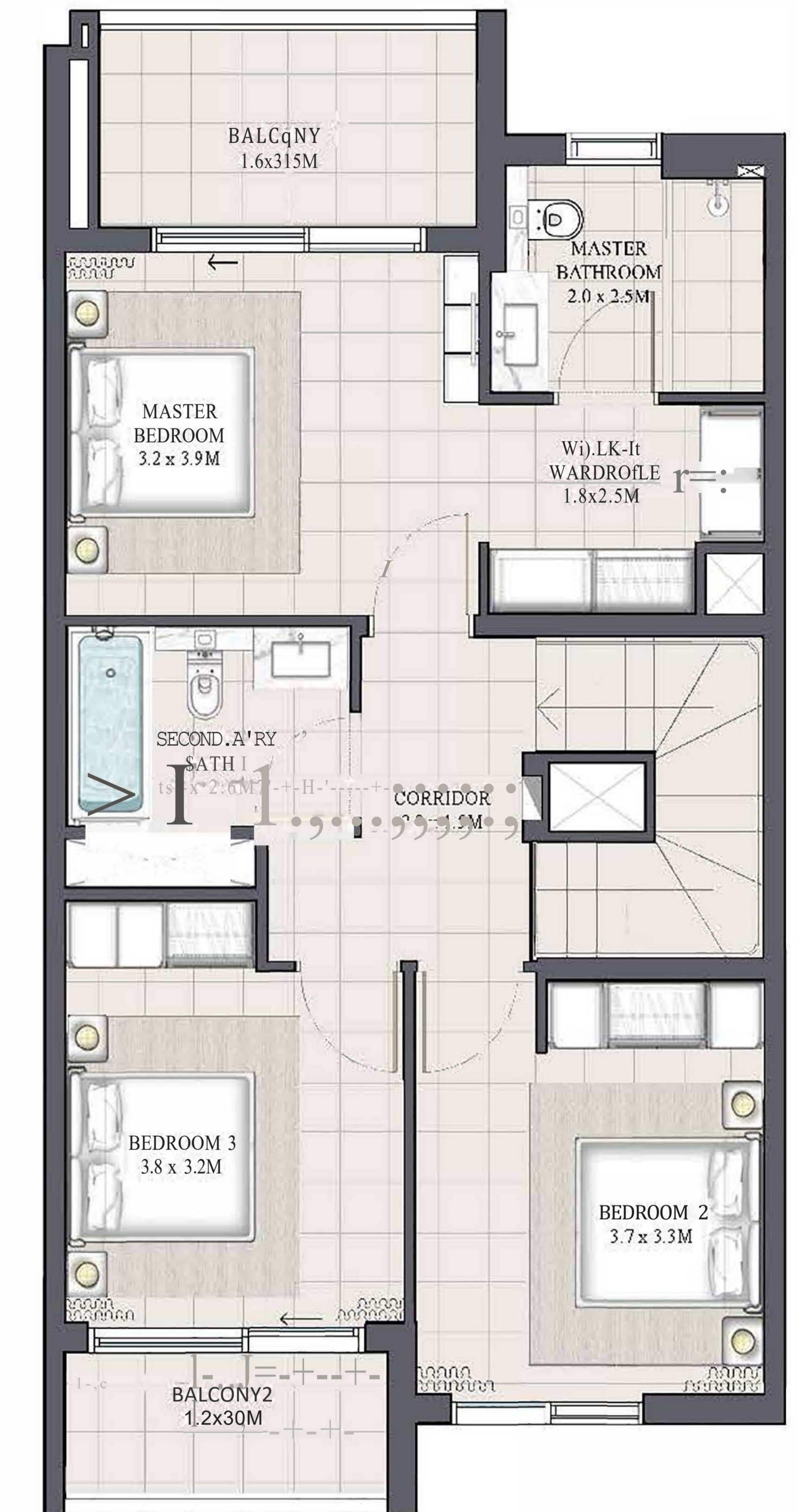

FIRST FLOOR

FLOOR PLAN 1. All dimensions are in imperial and metric, and measured from finish to finish excluding construction tolerances. 2. All materials, dimensions, and drawings are approximate only. 3. Information is subject to change without notice, at developer's absolute discretion. 4. Actual area may vary from the stated area. 5. Drawings not to scale. 6. All images used are for illustrative purposes only and do not represent the actual size, features, specifications, fittings, and furnishings. 7. The developer reserves the right to make revisions / alterations, at it's absolute discretion, without any liability whatsoever.

# ANYA 2

ARABIAN RANCHES III

## IRIS TOWNHOUSE 3 BEDROOM IM MIRRORED

UNIT	TOTAL AREA	
4PLEX - TH03		
6PLEX - TH05	2038.79 SQFT	189.41 SQM
8PLEX - TH07		

### KEY PLAN

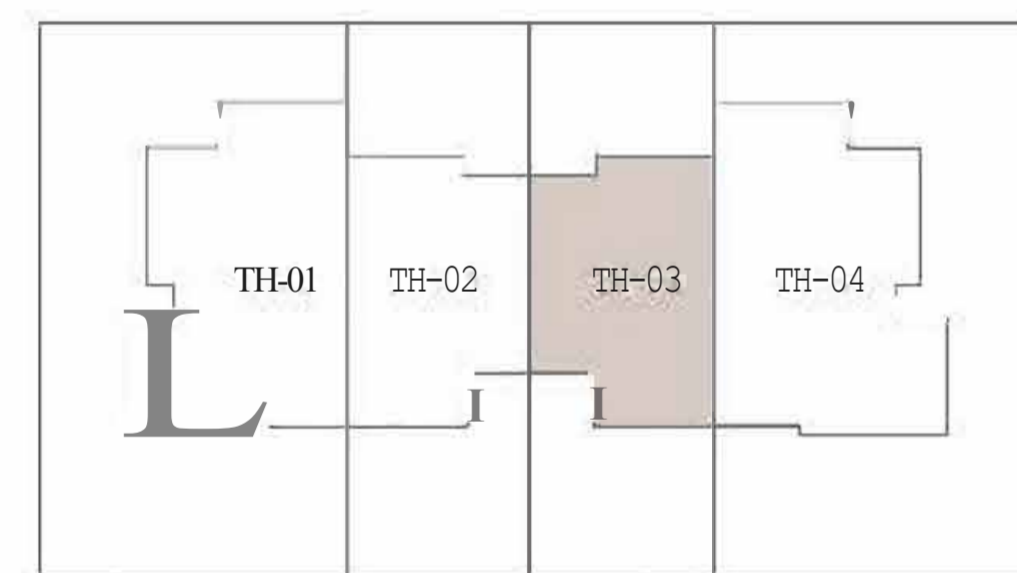

4PLEX - TH03

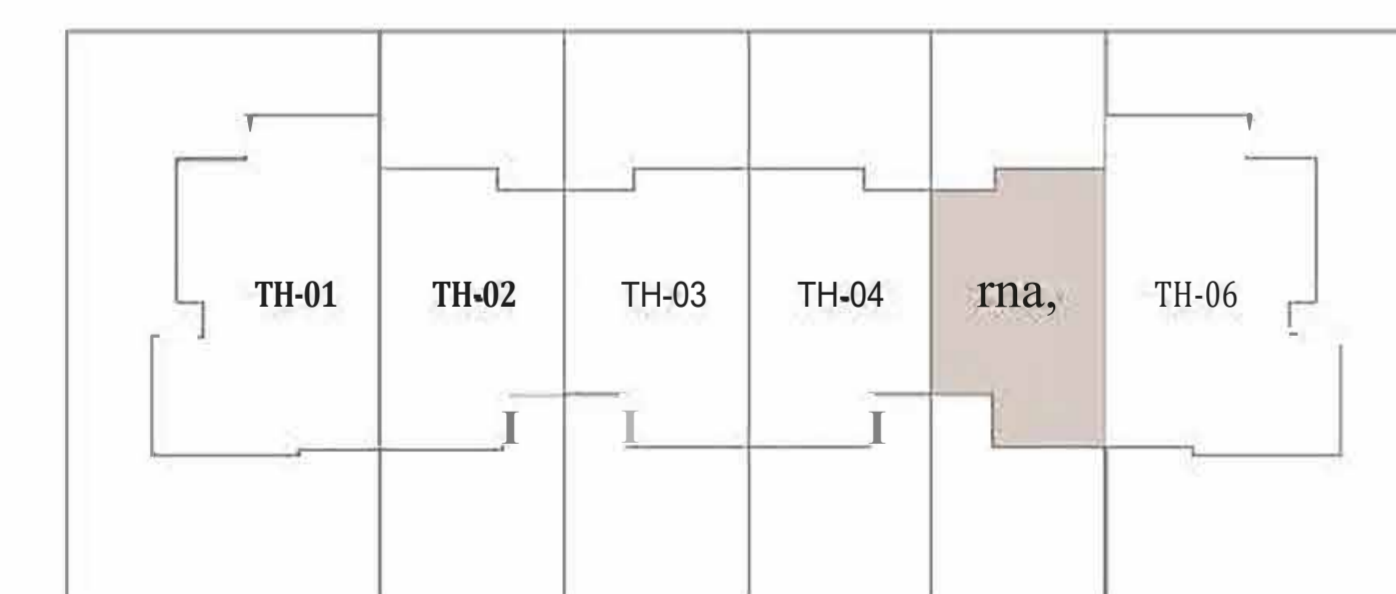

6PLEX - TH05

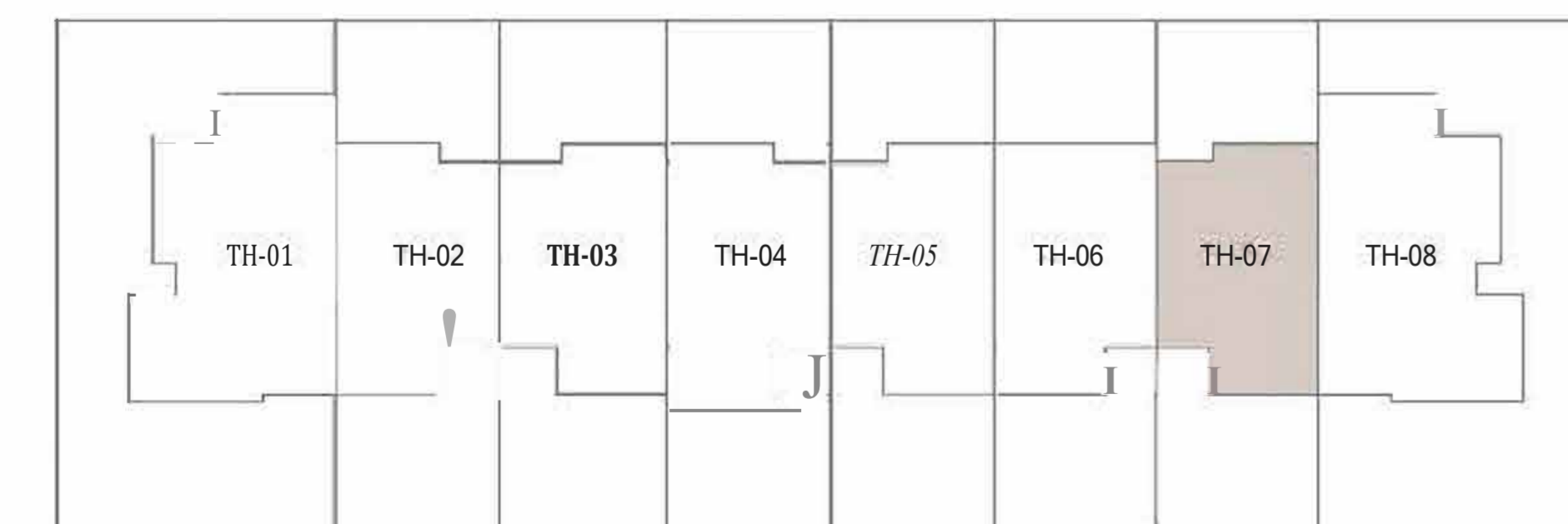

8PLEX - TH07



GROUND FLOOR



FIRST FLOOR

FLOOR PLAN 1. All dimensions are in imperial and metric, and measured from finish to finish excluding construction tolerances. 2. All materials, dimensions, and drawings are approximate only. 3. Information is subject to change without notice, at developer's absolute discretion. 4. Actual area may vary from the stated area. 5. Drawings not to scale. 6. All images used are for illustrative purposes only and do not represent the actual size, features, specifications, fittings, and furnishings. 7. The developer reserves the right to make revisions / alterations, at it's absolute discretion, without any liability whatsoever.

# ANYA 2

ARABIAN RANCHES III

IRIS

TOWNHOUSE

## 3 BEDROOM 2

UNIT	TOTAL AREA	
6PLEX - TH03		
8PLEX - TH03	2036.42 SQFT	189.19 SQM
8PLEX - TH05		

### KEY PLAN

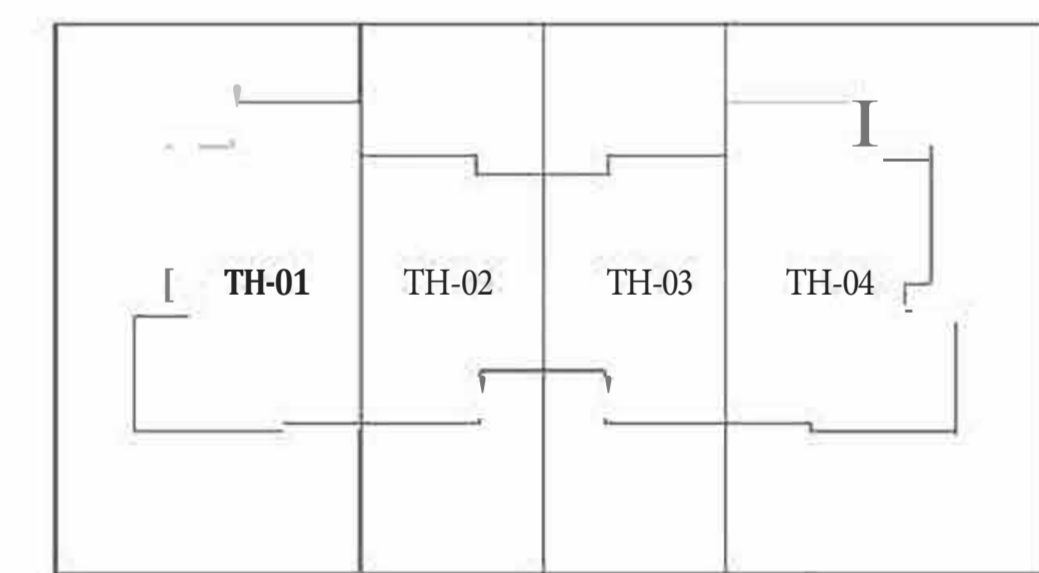

4PLEX

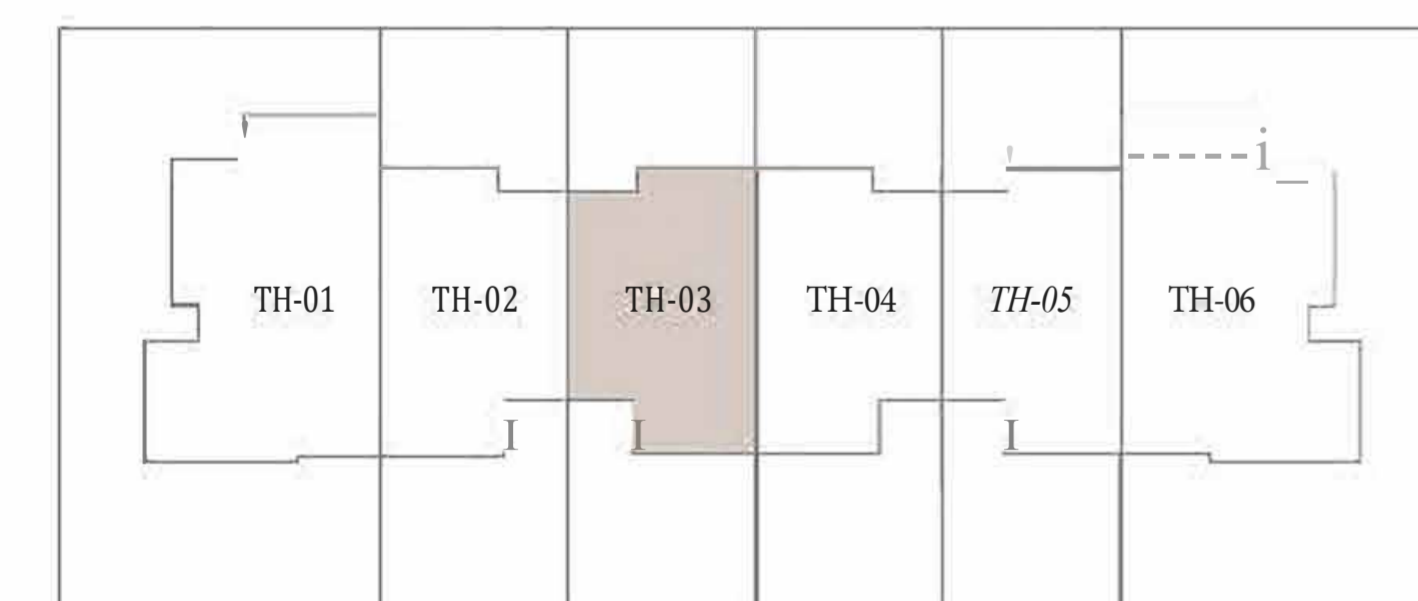

6PLEX - TH03

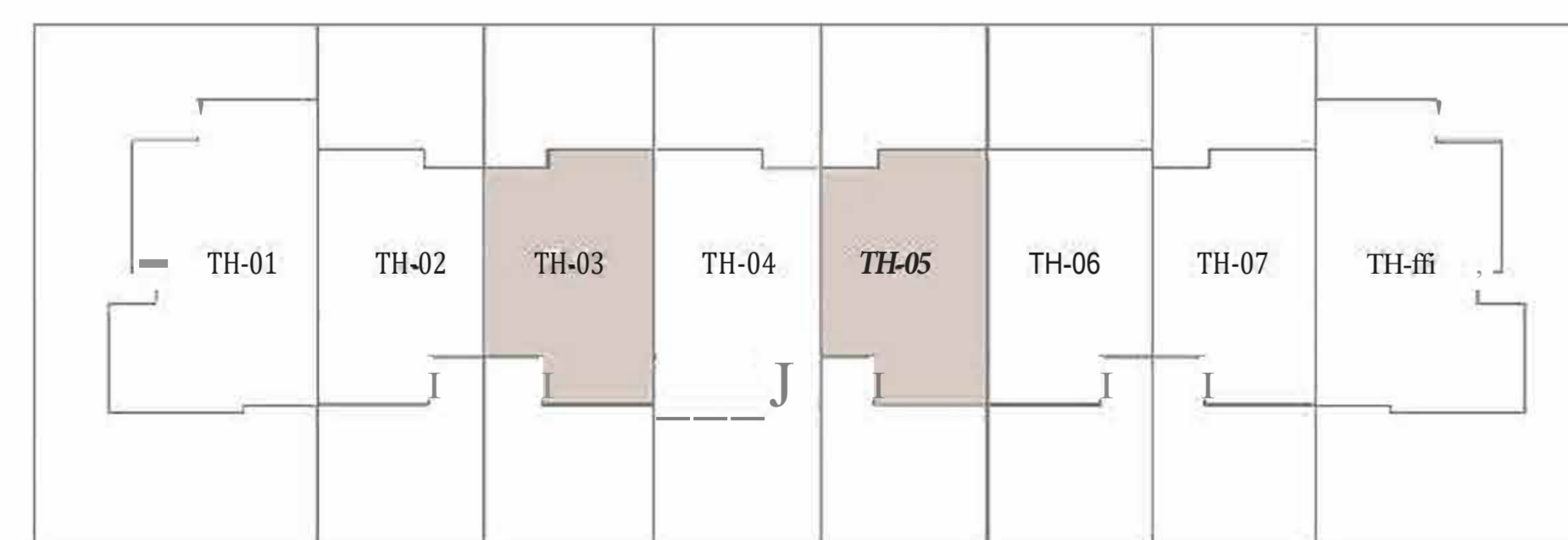

8PLEX - TH03, TH05

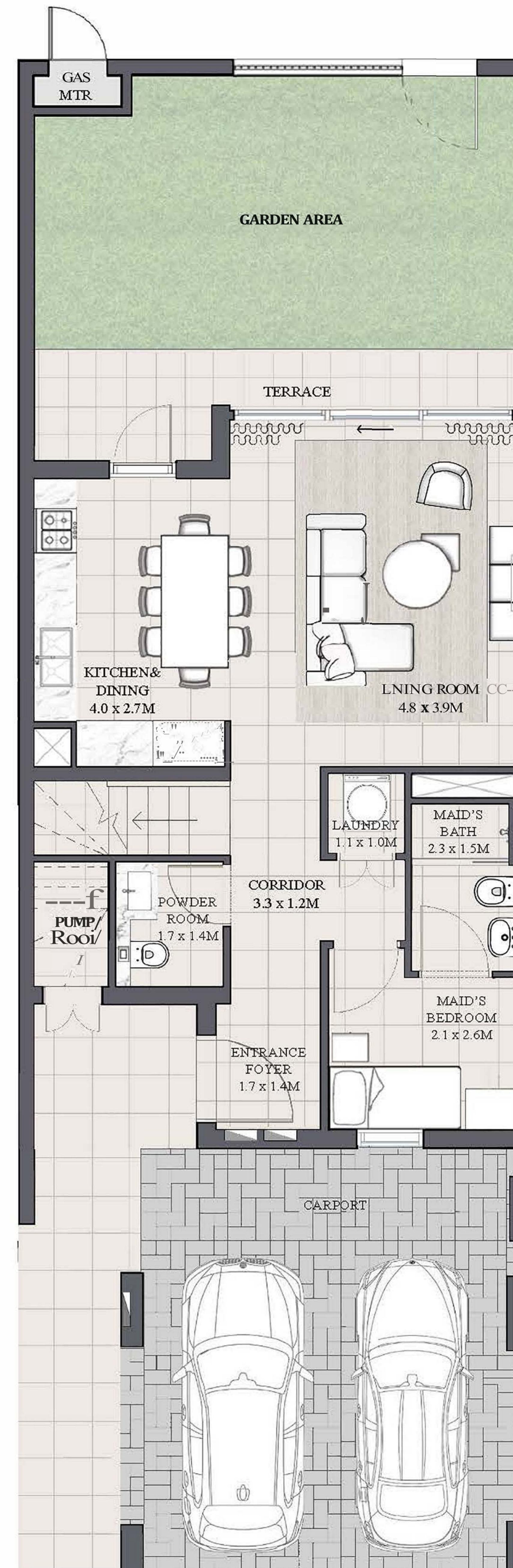

GROUND FLOOR

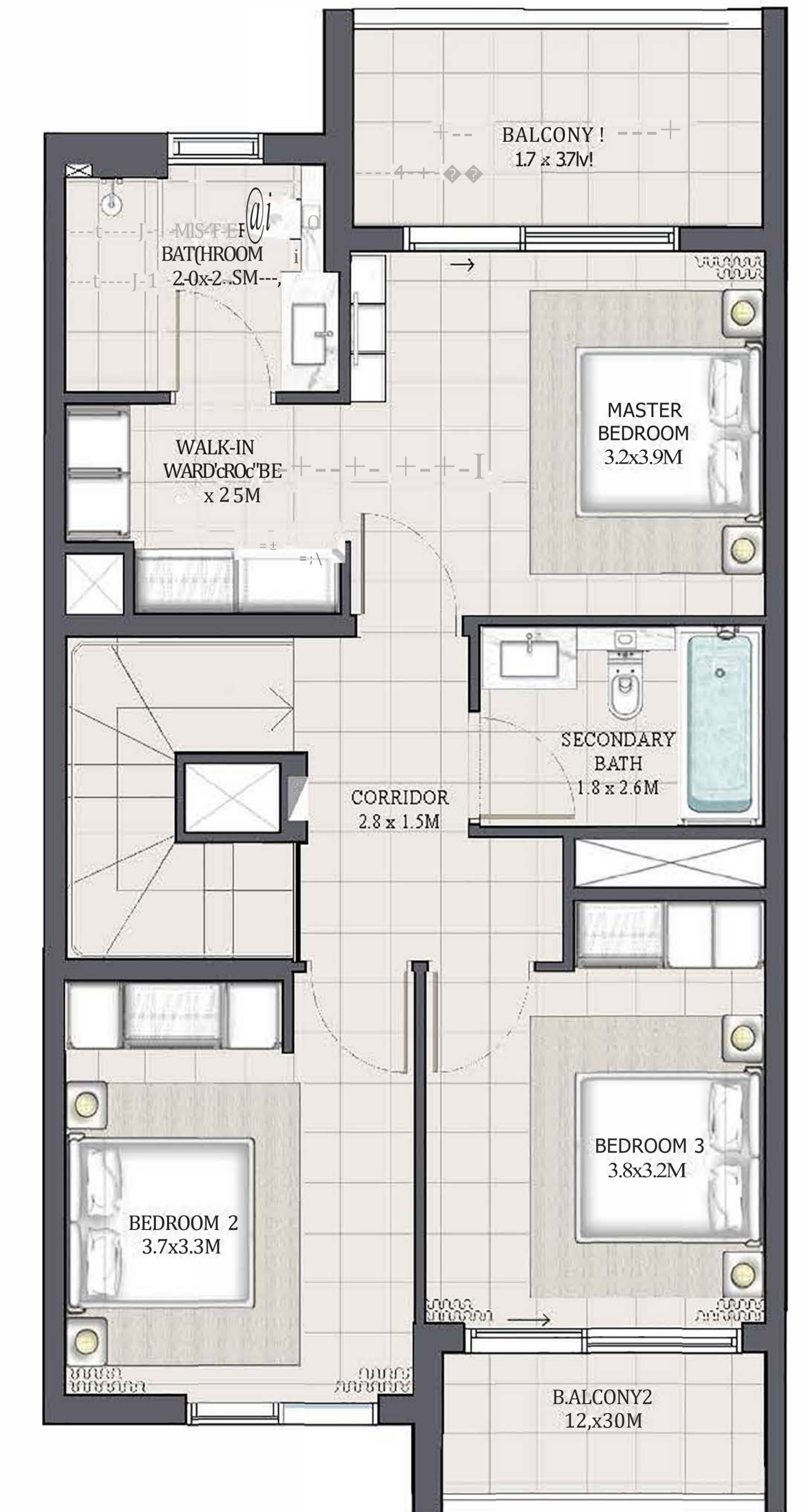

FIRST FLOOR

FLOOR PLAN 1. All dimensions are in imperial and metric, and measured from finish to finish excluding construction tolerances. 2. All materials, dimensions, and drawings are approximate only. 3. Information is subject to change without notice, at developer's absolute discretion. 4. Actual area may vary from the stated area. 5. Drawings not to scale. 6. All images used are for illustrative purposes only and do not represent the actual size, features, specifications, fittings, and furnishings. 7. The developer reserves the right to make revisions / alterations, at it's absolute discretion, without any liability whatsoever.

# ANYA 2

ARABIAN RANCHES III

## IRIS TOWNHOUSE 3 BEDROOM 2M

UNIT	TOTAL AREA	
6PLEX - TH04		
8PLEX - TH04	2036.42 SQFT	189.19 SQM
8PLEX - TH06		

### KEY PLAN

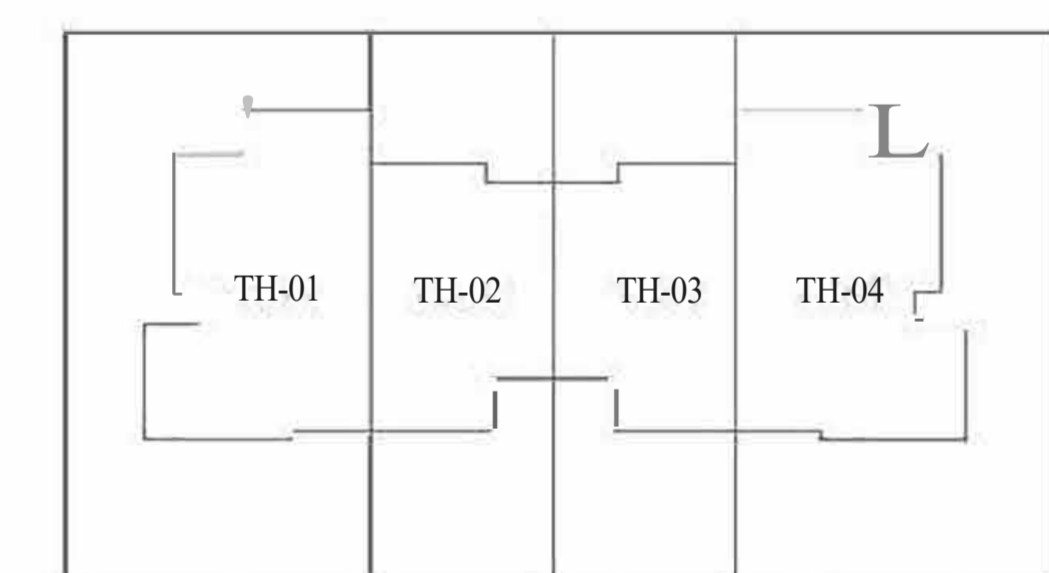

4PLEX

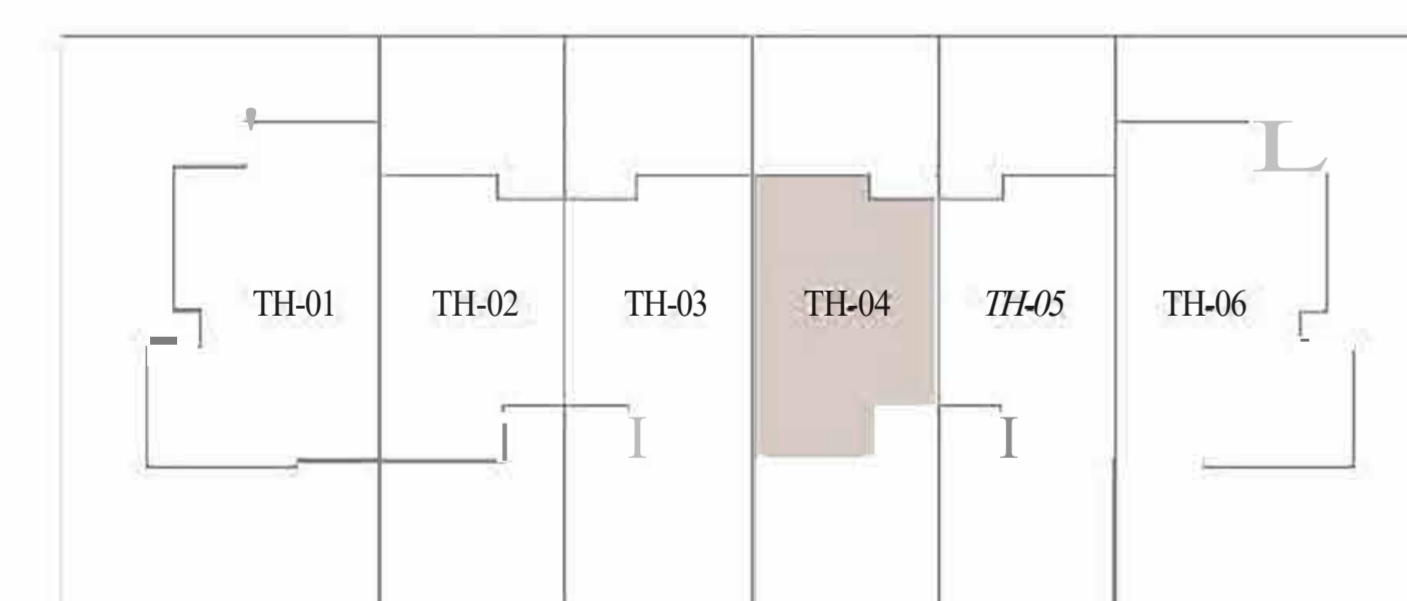

6PLEX - TH04

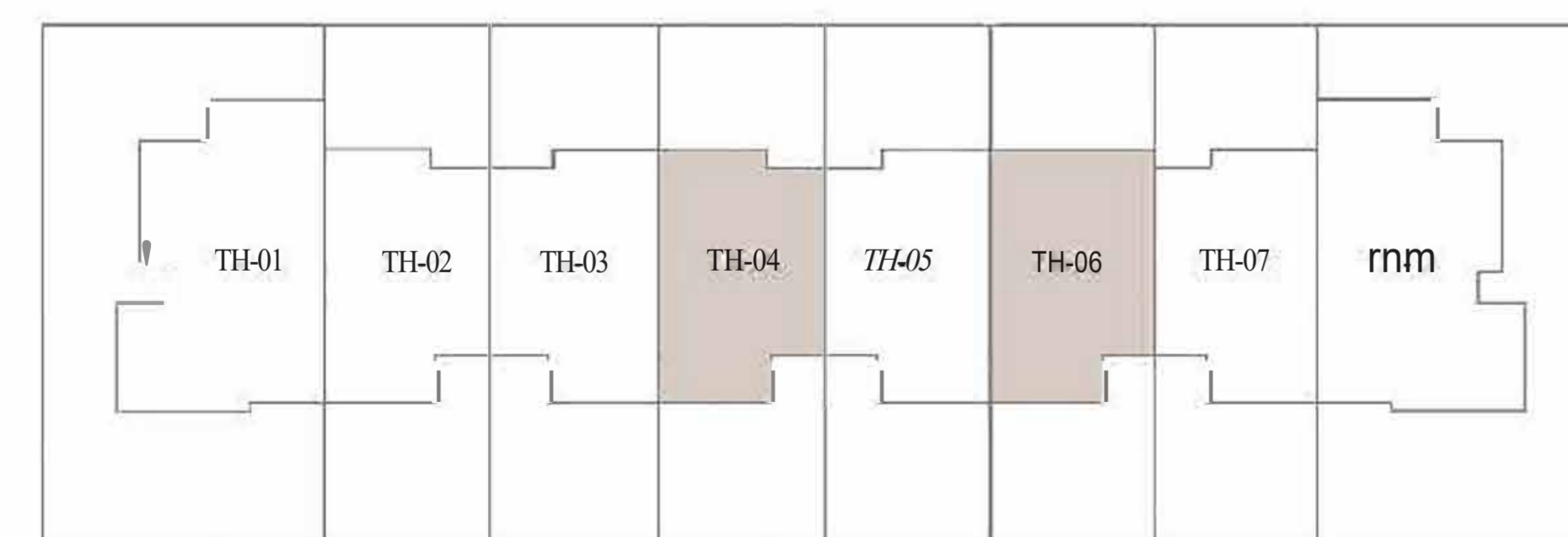

8PLEX - TH04, TH06

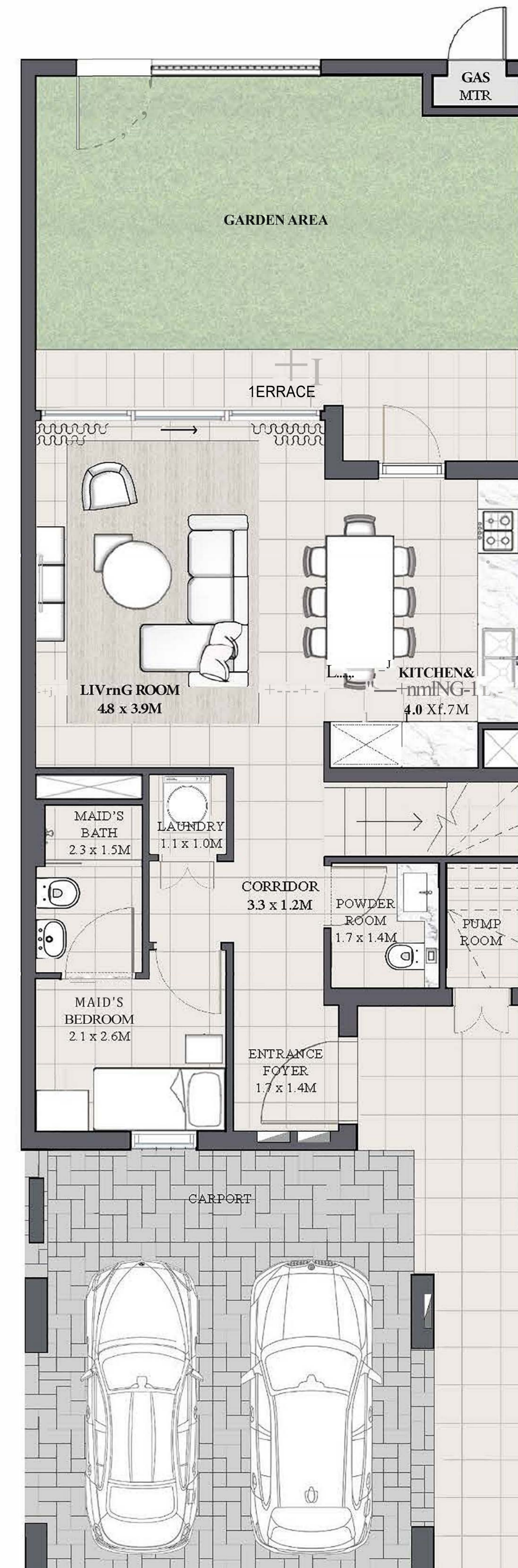

GROUND FLOOR

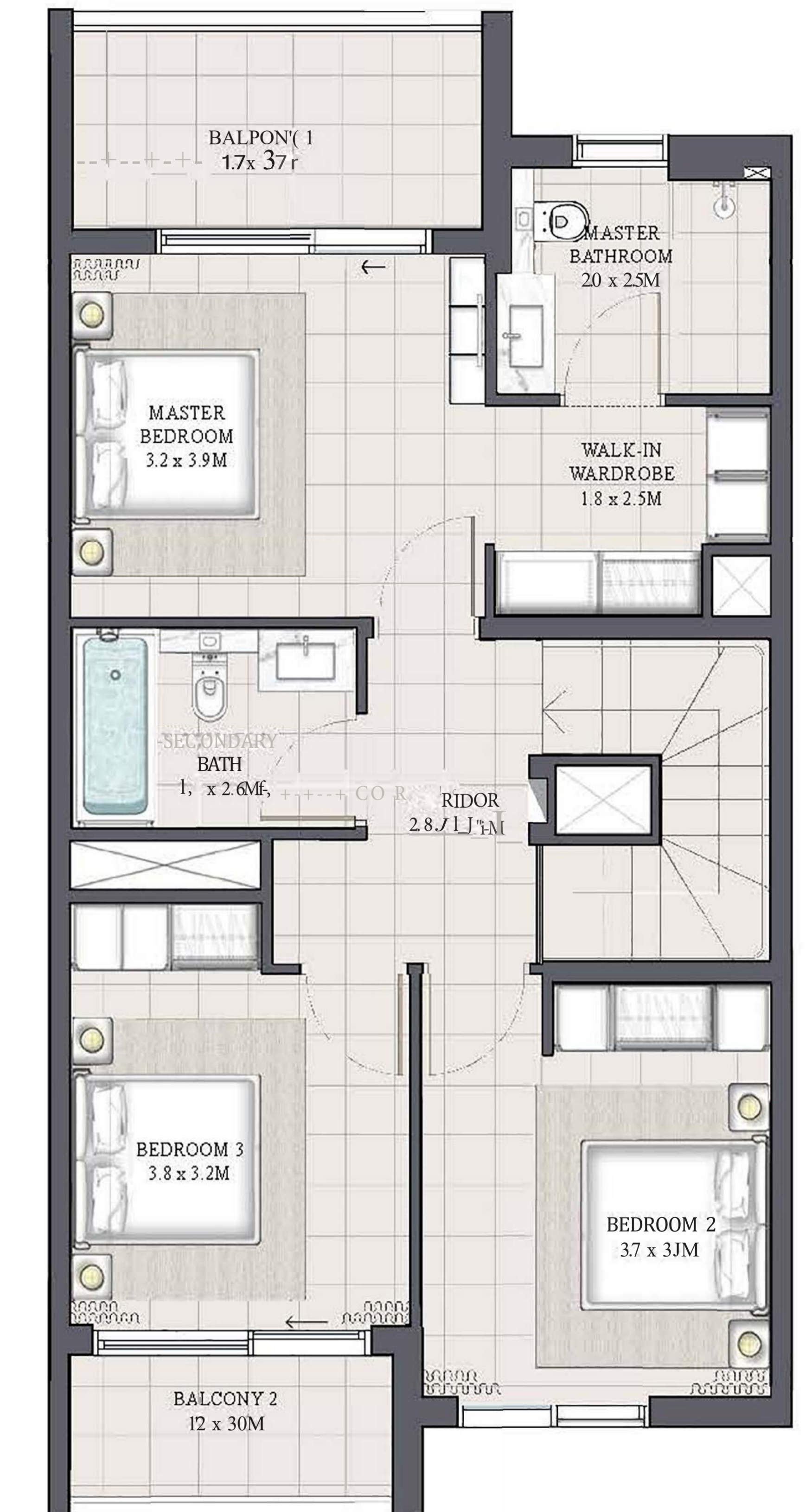

FIRST FLOOR

FLOOR PLAN 1. All dimensions are in imperial and metric, and measured from finish to finish excluding construction tolerances. 2. All materials, dimensions, and drawings are approximate only. 3. Information is subject to change without notice, at developer's absolute discretion. 4. Actual area may vary from the stated area. 5. Drawings not to scale. 6. All images used are for illustrative purposes only and do not represent the actual size, features, specifications, fittings, and furnishings. 7. The developer reserves the right to make revisions / alterations, at its absolute discretion, without any liability whatsoever.